

NOTICE DE MONTAGE
INSTRUCTIONS FOR ASSEMBLY
MONTAGEANLEITUNG
GEBRUIKSAANWIJZING
ISTRUZIONI DI MONTAGGIO
INSTRUCCIONES DE MONTAJE
INSTRUCOES DE MONTAGEM

buronomic
FABRICANT FRANÇAIS
N° DV40707/03

CONCEPTION ET REALISATION BUREAU D'ETUDES BURONOMIC

GARANTIE (vices cachés)
_ Référence produit à nous communiquer impérativement en cas de litige :
Voir étiquette apposée au dos du produit

GARANTIE (defekt)
_ In the event of complaint, it is essential to mention the product reference :
See label affixed to the back of the product.

GARANTIE (fabrikationsfeil)
_ Im streifall sit uns die produktreferenz mitzuteilen :
Siehe etikett auf produckruckseite.

WAARBORG (de verborgen gebreken)
_ Vermeld in geval van klachten altijd het productnummer :
Zie label op de achterzijde van het product

GARANZIA (vizi occulti)
_ Specificare obbligatoriamente il riferimento prodotto in caso di contestazioni :
Si veda l'etichetta applicata dietro il prodotto

GARANTIA (defectos ocultos)
_ Referencia de producto citese obligatoriamente en caso de reclamacion :
Ver etiqueta en la parte posterior do produto.

GARANTIA (vices ocultos)
_ Em caso de reclamacao indiq-nos imperativamente a referencia do produto :
Ver etiqueta fixada na parte posterior do produto

PMR à Droite

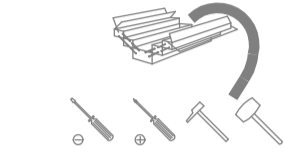
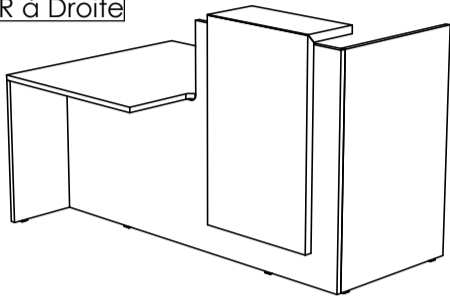

PMR à Gauche

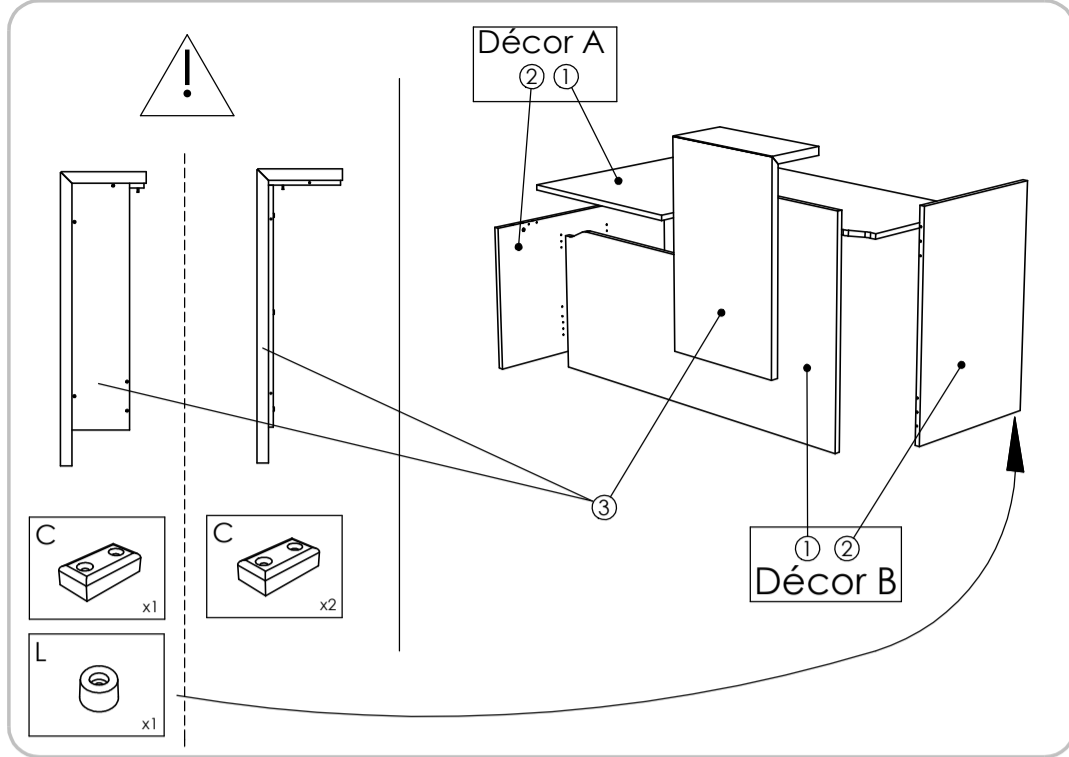
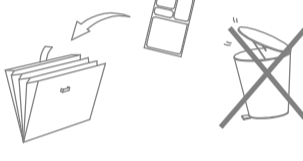
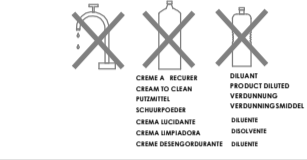

NOMENCLATURE (Parts list)
(Stückliste)
(Onderdelenlijst)
(Nomenclatura)
(Lista de peças)

Rep.	Pièce	Qté
1	PLAN PRINCIPAL	2
2	COTE	2
3	SATELLITE	1

QUINCAILLERIE (Hardware)
(Beschläge)
(Izzerwaren)
(Ferramenta)
(Herrajes)
(Quinquilharia)

Rep.	Pièce	Qté	A	B	C	D	E	F	G	H	I	J	K	L	M	N	O	P	Q	R
A	EQUERRE de FIXATION	6																		
B	VIS Euro L 13mm	36																		
C	PATIN à VISSER	6																		
D	Vis TF 3x20	12																		
E	Taquet Ø5x30	2																		
F	Vis 4x40	1																		
G	Cache Ø5	28																		
H	Coussinet verre	6																		
I	Excentrique court	4																		
J	Goujon métal	4																		
K	Cache excent.	4																		
L	Butée	1																		
M	Vis TCB 4x25	1																		

AIDE

HELP
HILFE
HULP
AYUDA
AJUDA
AIUTO

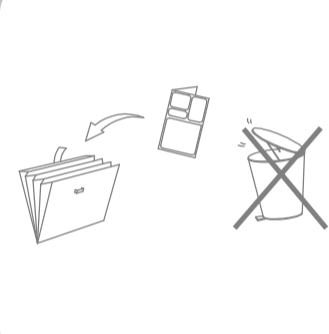
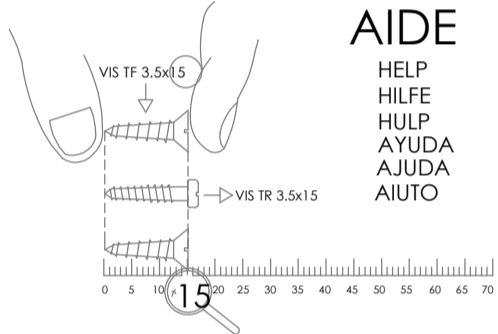

1 PMR à Droite et à Gauche

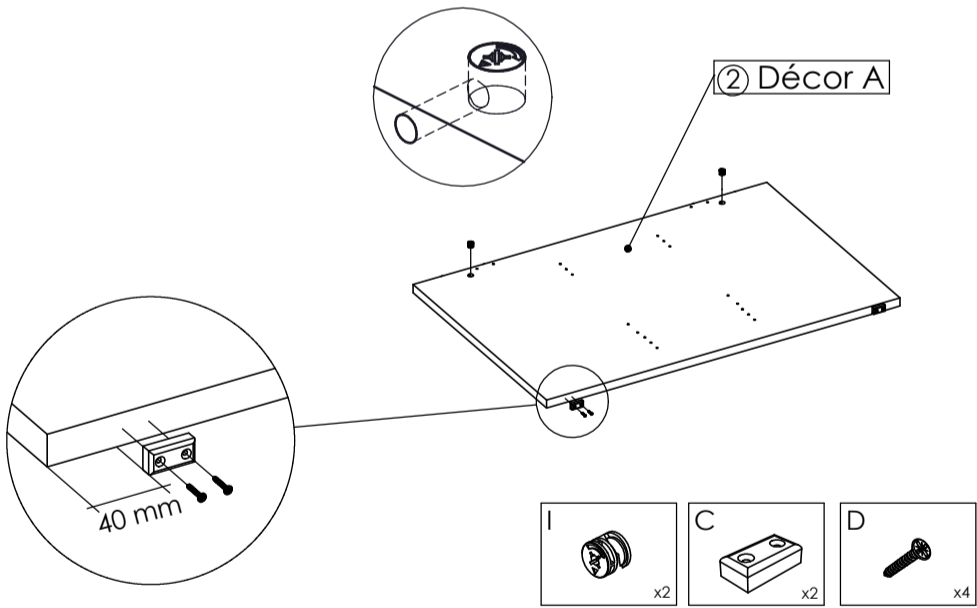

2 PMR à Droite PMR à Gauche

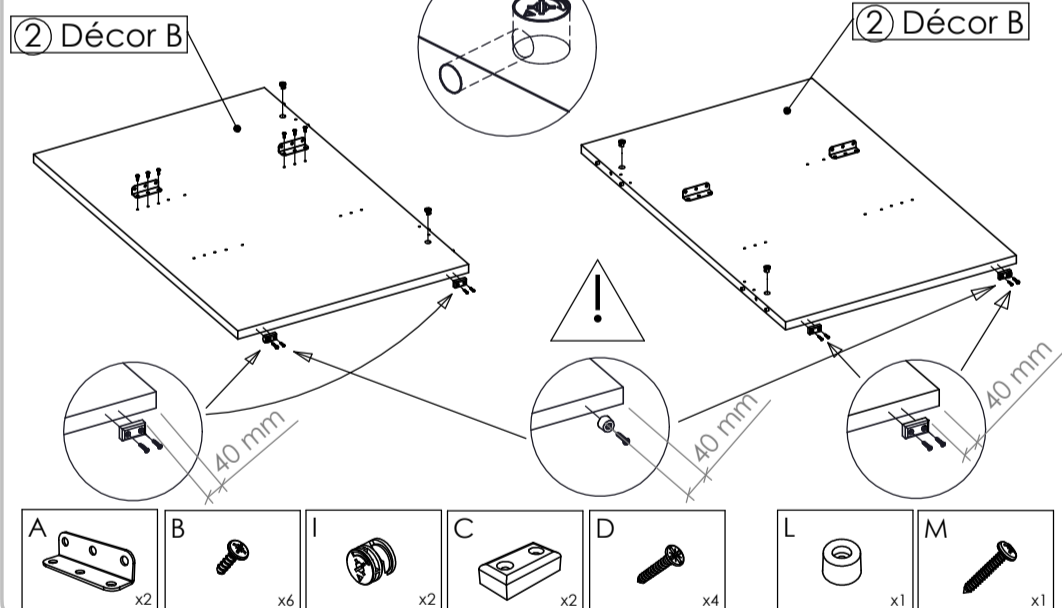

3 PMR à Droite

PMR à Gauche

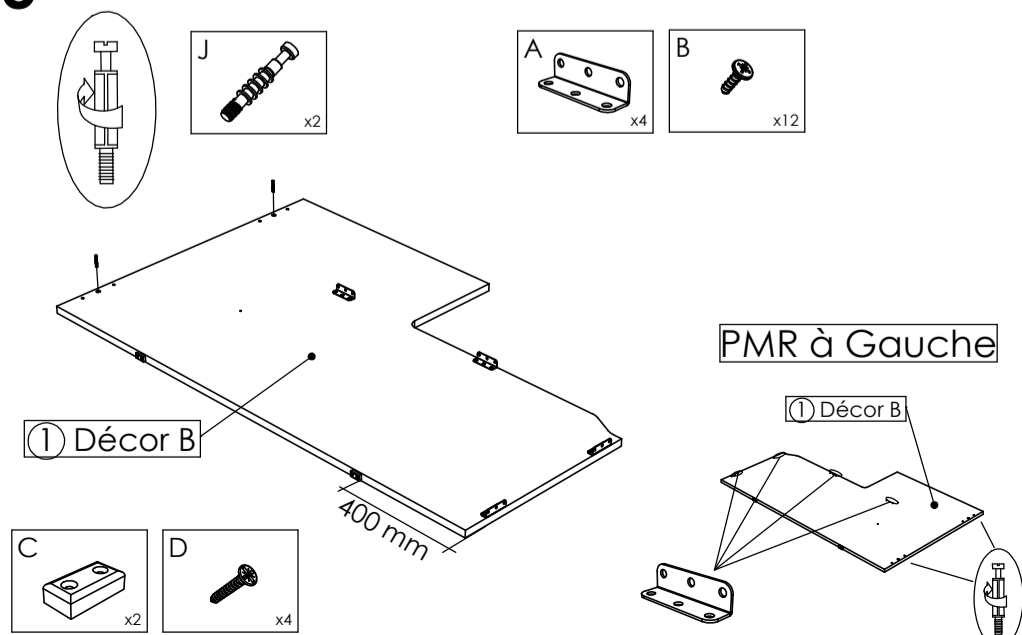

4 Décor B PMR à Droite

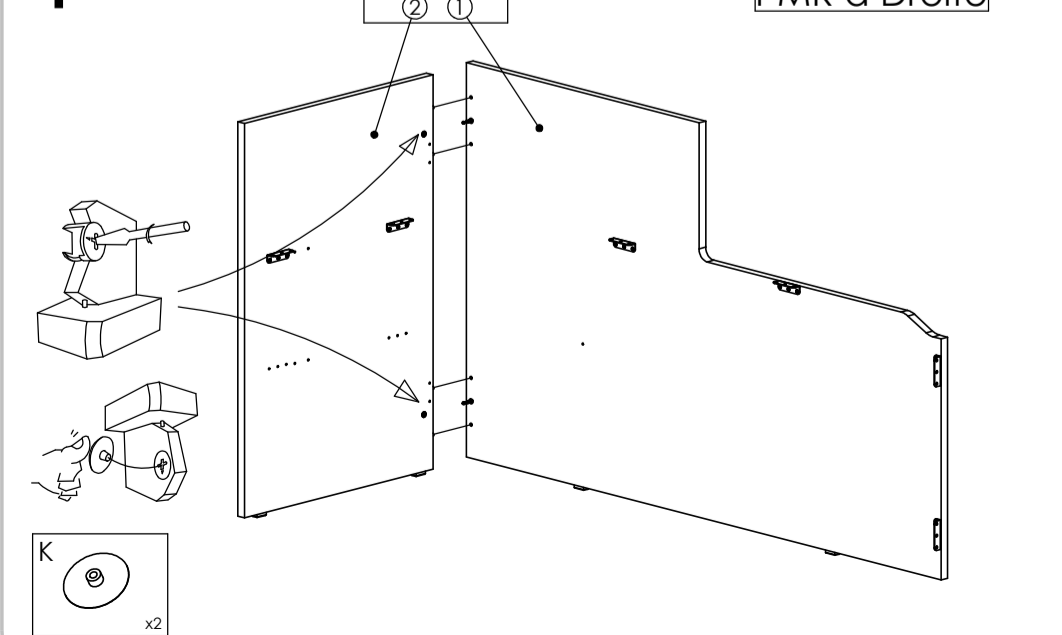

NOTICE DE MONTAGE
INSTRUCTIONS FOR ASSEMBLY
MONTAGEANLEITUNG
GEBRUIKSAANWIJZING
ISTRUZIONI DI MONTAGGIO
INSTRUCCIONES DE MONTAJE
INSTRUCCOES DE MONTAGEM

buronomic
FABRICANT FRANÇAIS
N° DV40872/01

CONCEPTION ET REALISATION BUREAU D'ETUDES BURONOMIC

GARANTIE (vices cachés)
_ Référence produit à nous communiquer impérativement en cas de litige :
Voir étiquette apposée au dos du produit

GARANTEE (defekt)
_ In the event of complaint, it is essential to mention the product reference :
See label affixed to the back of the product.

GARANTIE (fabrikationfelher)
_ Im streitfall sit uns die produktreferenz mitzuteilen :
Siehe etikett auf produktruckseite.

WAARBORG (de verborgen gebreken)
_ Vermeld in geval van klachten altijd het productnummer :
Zie label op de achterzijde van het product

GARANZIA (vizi occulti)
_ Specificare obbligatoriamente il riferimento prodotto in caso di contestazioni :
Si veda l'etichetta applicata dietro il prodotto

GARANTIA (defectos oculos)
_ Referencia de producto citese obligatoriamente en caso de reclamacion :
Ver etiqueta en la parte posterior del producto.

GARANTIA (vicios ocultos)
_ Em caso de reclamacao indiqu-nos imperativamente a referencia do produto :
Ver etiqueta fixada na parte posterior do produto

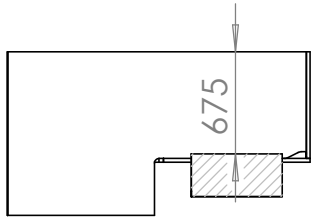
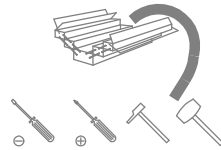
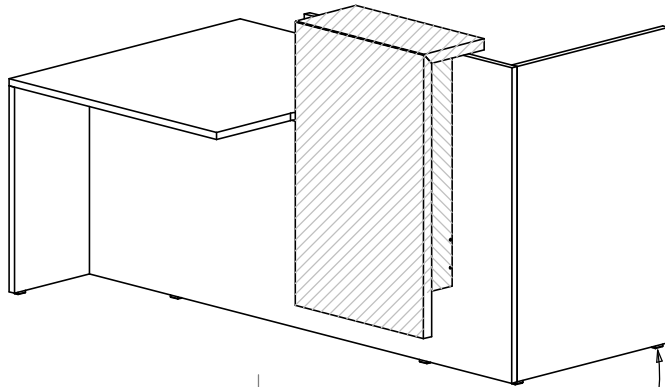

Voir DV40707

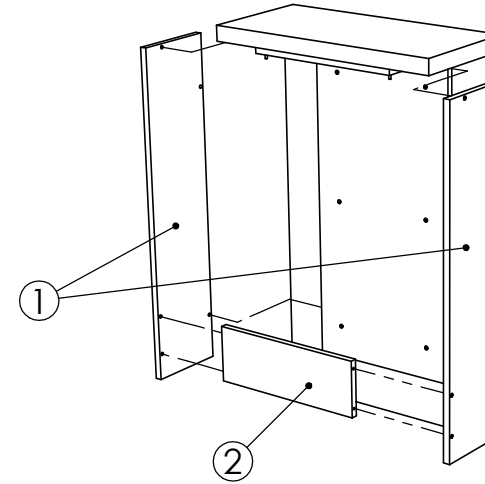

NOMENCLATURE
(Parts list)
(Stückliste)
(Onderdelenlijst)
(Nomenclatura)
(Lista de peças)

Rep.	Pièce	Qté
1	BANDEAU LATERAL	2
2	BANDEAU FRONTAL	1

QUINCAILLERIE

(Hardware)
(Beschiège)
(Ijzerwaren)
(Herramienta)
(Ferrajes)
(Quinquilharia)

Rep.	Pièce	Qté	A	B	C
A	Vis 7x50	10			
B	Cache vis	10			
C	Clé 6 pans 4mm	1			
Rep.	Pièce	Qté	G	H	I
E	Taquet Ø5x30	2			
F	Vis 4x40	1			

AIDE

HELP
HILFE
HULP
AYUDA
AJUDA
AIUTO

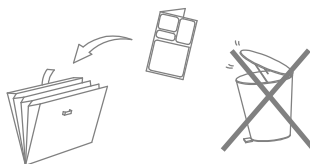
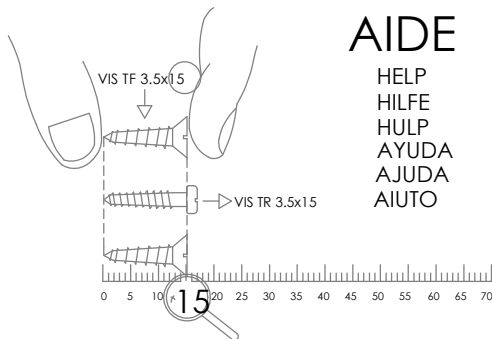

1

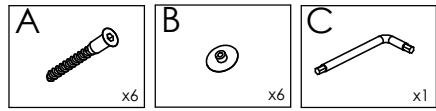
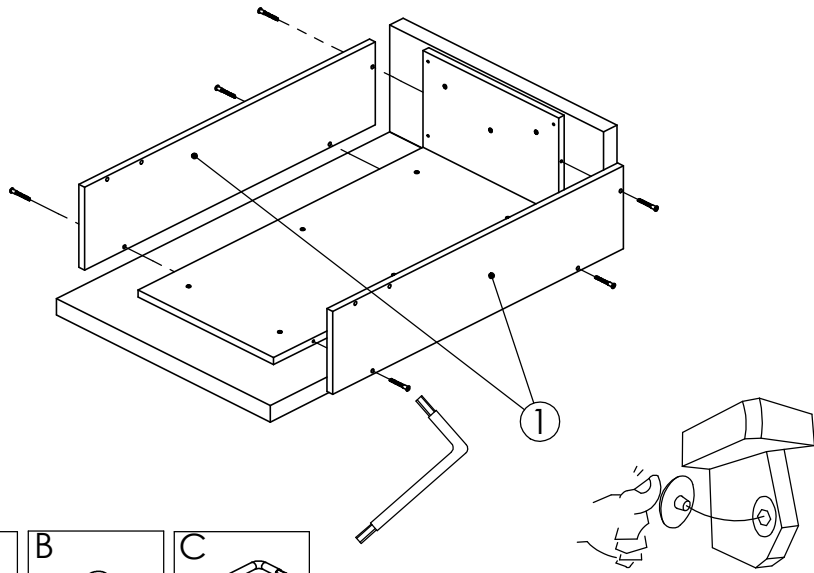

2

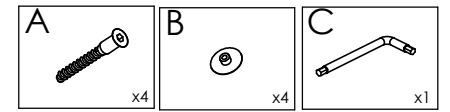
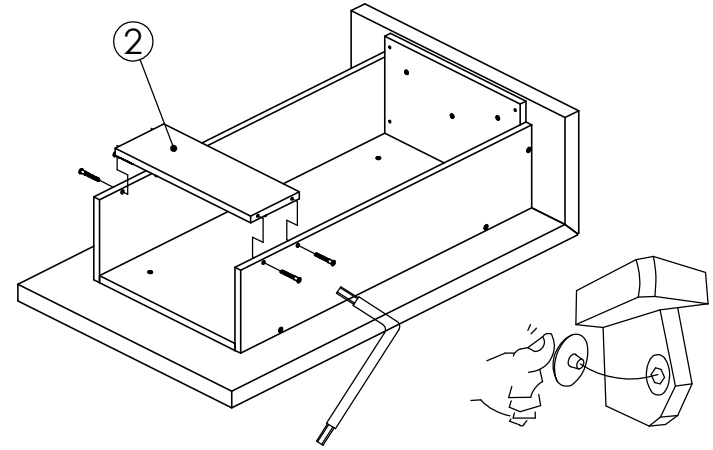

3

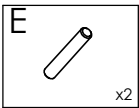
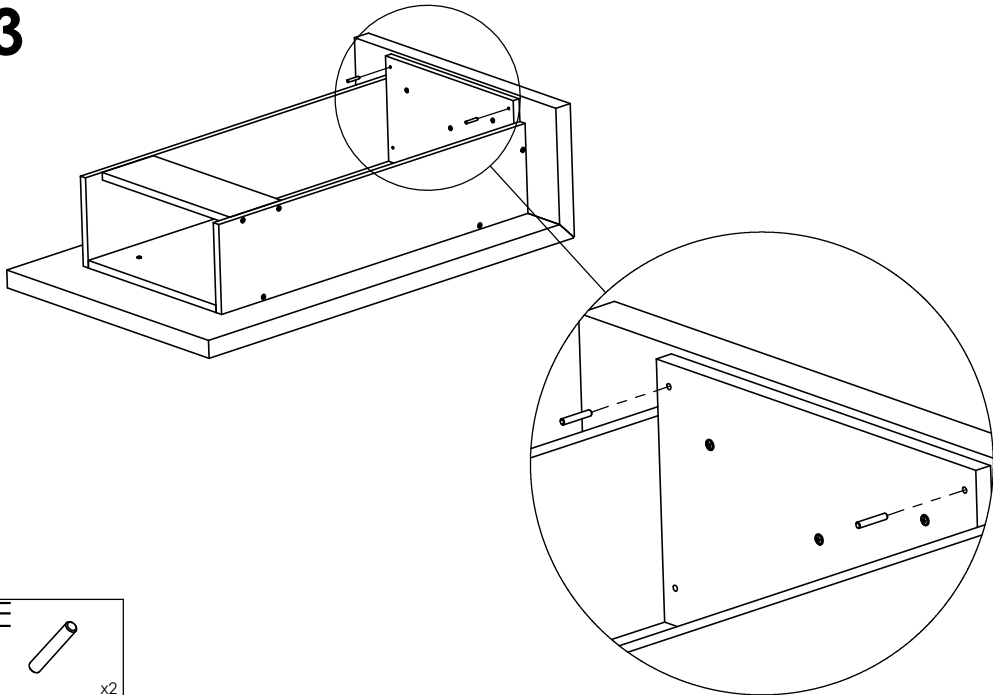

4

