

NOTICE DE MONTAGE
INSTRUCTIONS FOR ASSEMBLY
MONTAGEANLEITUNG
GEBRUIKSAANWIJZING
ISTRUZIONI DI MONTAGGIO
INSTRUCCIONES DE MONTAJE
INSTRUCCIONES DE MONTAJE

buronomic
N° DV40684/02

CONCEPTION ET REALISATION BUREAU D'ETUDES BURONOMIC

GARANTEE (vices cachés)
_ Référence produit à nous communiquer impérativement en cas de litige :
Voir étiquette apposée au dos du produit

GARANTEE (defekt)
_ In the event of complaint, it is essential to mention the product reference :
See label affixed to the back of the product.

GARANTEE (fabrikationfehler)
_ Im streitfall sit uns die produktreferenz mitzuteilen :
Siehe etikett auf produktseite.

WAARBORG (de verborgen getuigen)
_ Vermeld in geval van klachten altijd het productnummer :
Zie label op de achterzijde van het product

GARANZIA (vizi occulte)
_ Specificare obbligatoriamente il riferimento prodotto in caso di contestazioni :
Si veda l'etichetta applicata dietro il prodotto

GARANTIA (defectos ocultos)
_ Referencia de producto citese obligatoriamente en caso de reclamacion :
Ver etiqueta en la parte posterior del producto.

GARANTIA (vissza eszűrtve)
_ Em caso de reclamacao inditu-nos imperativamente a referencia do produto :
Ver etiqueta fixada na parte posterior do produto

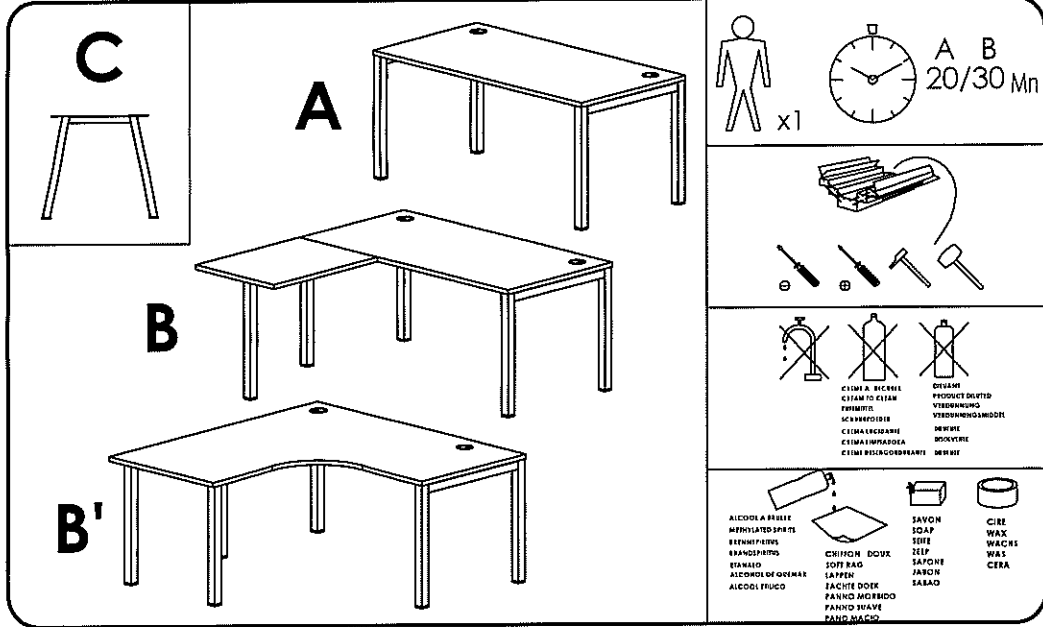
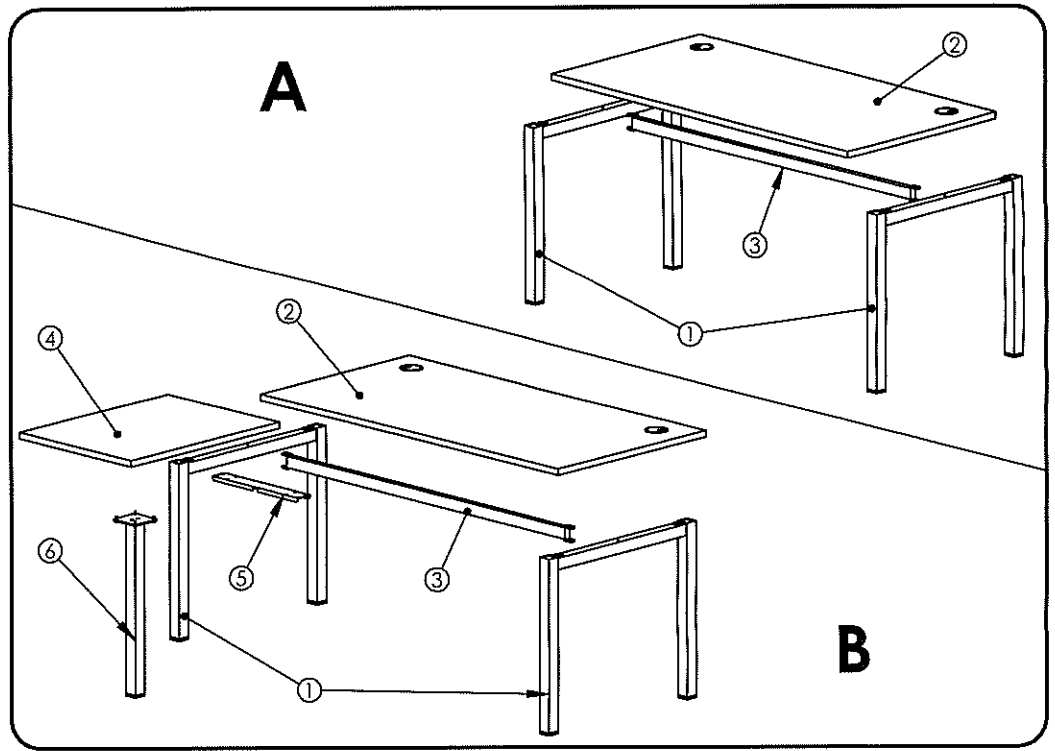

CLIMATISEREN
CLEAN TO CLEAN
FRÖHREN
SCHREIBEN
CLIMATISEREN
CLEAN TO CLEAN
FRÖHREN
SCHREIBEN
CLIMATISEREN
CLEAN TO CLEAN
FRÖHREN
SCHREIBEN

ALCOHOL A FRESE
REINIGUNGSMITTEL
BRANDPAPIER
STÄUBER
ALCOHOL DE QUEIMAR
ALCOHOL FRUCCO

SAVON
SOPH
SEIF
SAPONE
JABON
TAKAD

CIRE
WAX
WACKES
WAS
CERA

NOMENCLATURE (Parts list)
(Stückliste)
(Onderdelenlijst)
(Nomenclatura)
(Lista de peças)

A		
Rep.	Pièce	Qté
1	ARCHE 800	2
2	PLAN DE TRAVAIL	1
3	POUTRE	1

B		
Rep.	Pièce	Qté
4	Plan Retour 60x80	1
5	PLATINE LIAISON RETOUR	1
6	PIED 50X50	1

QUINCAILLERIE (Hardware)
(Beschläge)
(Izerwaren)
(Ferramentas)
(Herrajes)
(Quinquilharia)

A			A	B	C
Rep.	Pièce	Qté			
A	Vis TFHC M6x16	4			
B	Entretoise plastique	4	D	E	F
C	Entretoise adhésive	1			
D	Rondelle A1	4	G	H	I
E	Vis TFHC M6x65	4			
F	Clé 6 pans 4mm	1	J	K	L

B			M	N	O
Rep.	Pièce	Qté			
F	Clé 6 pans 4mm	1			
G	Vis TFHC M6x20	2	P	Q	R
H	VIS TBHC M6x16	8			

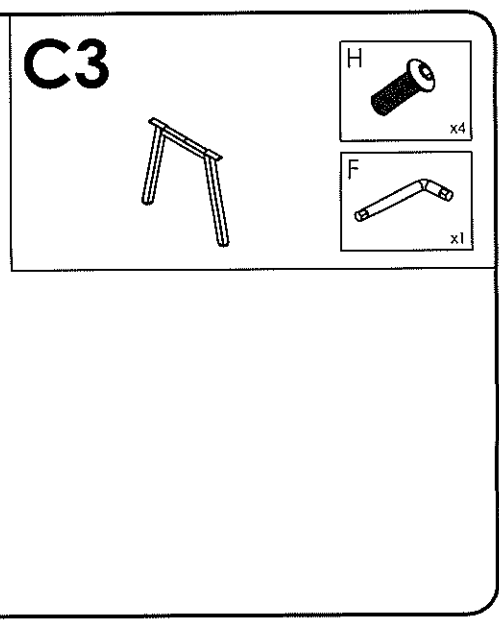
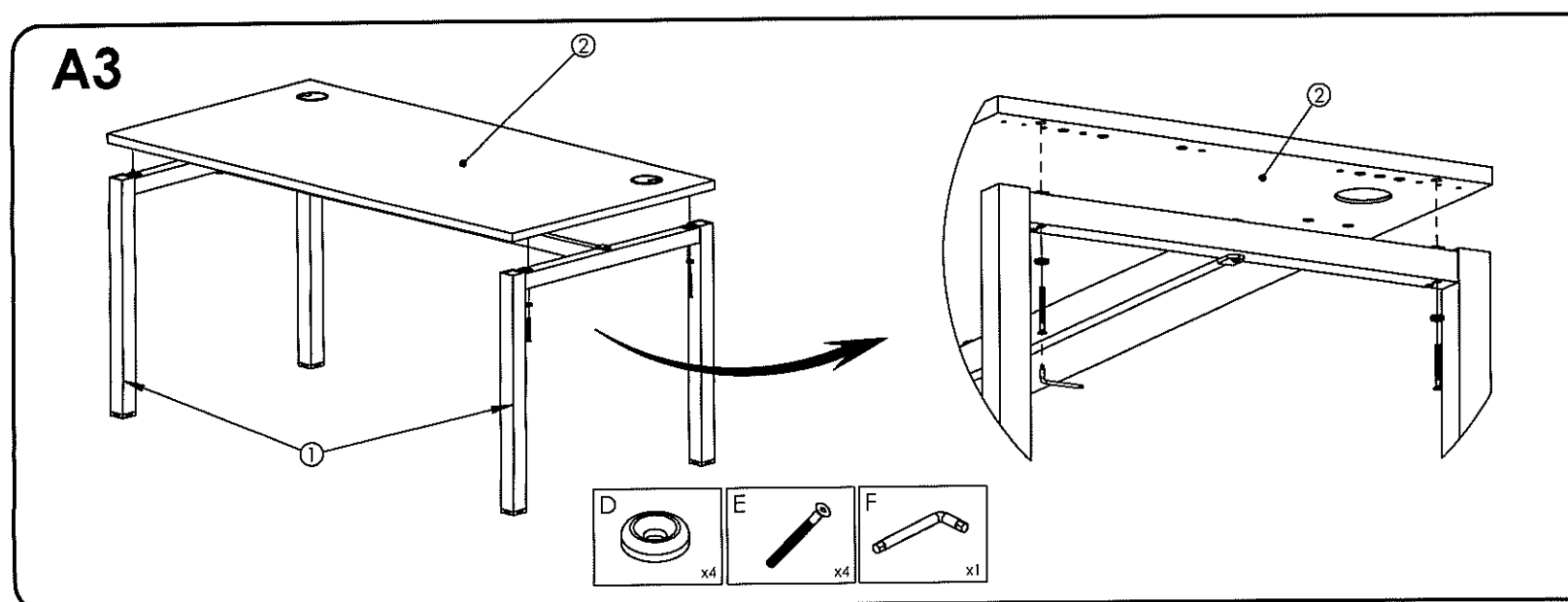
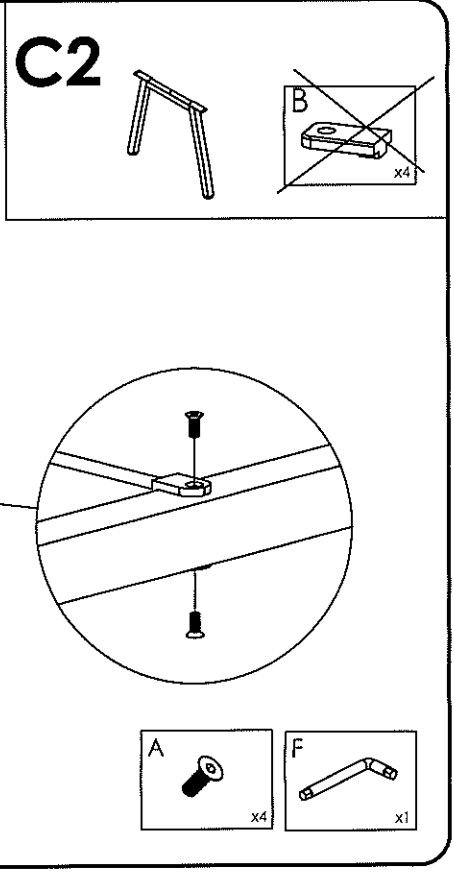
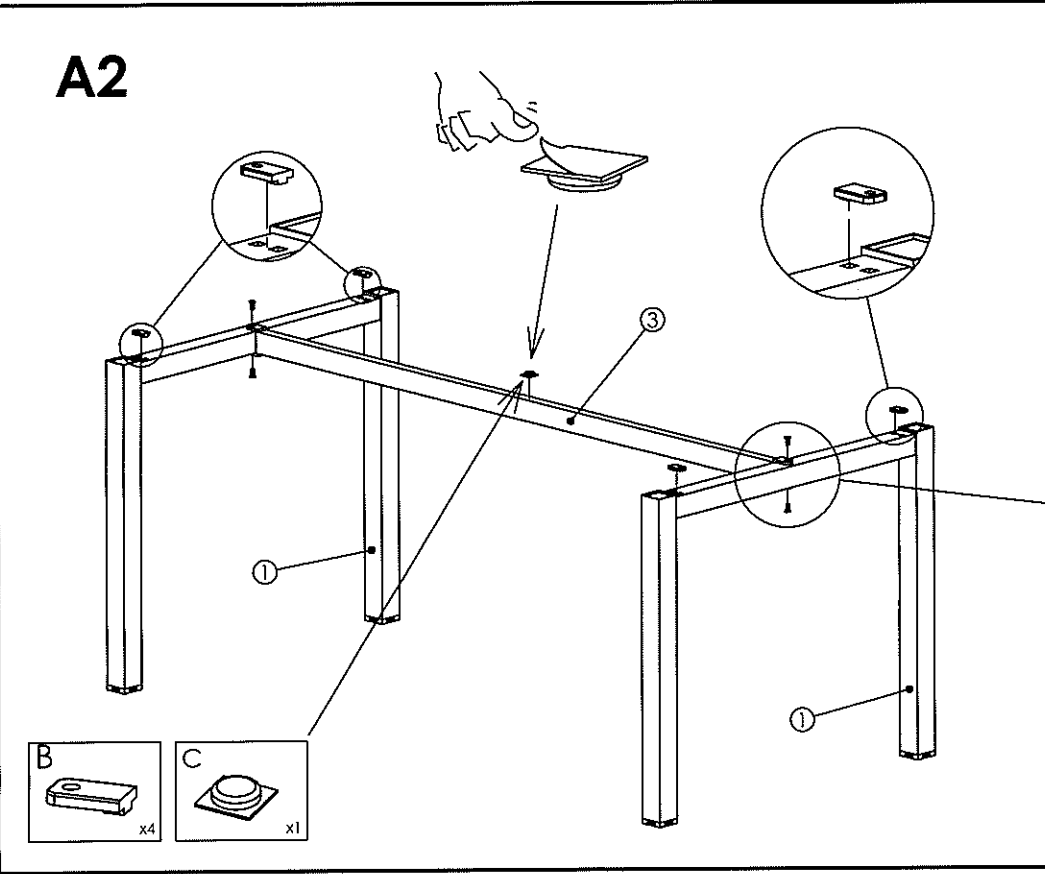
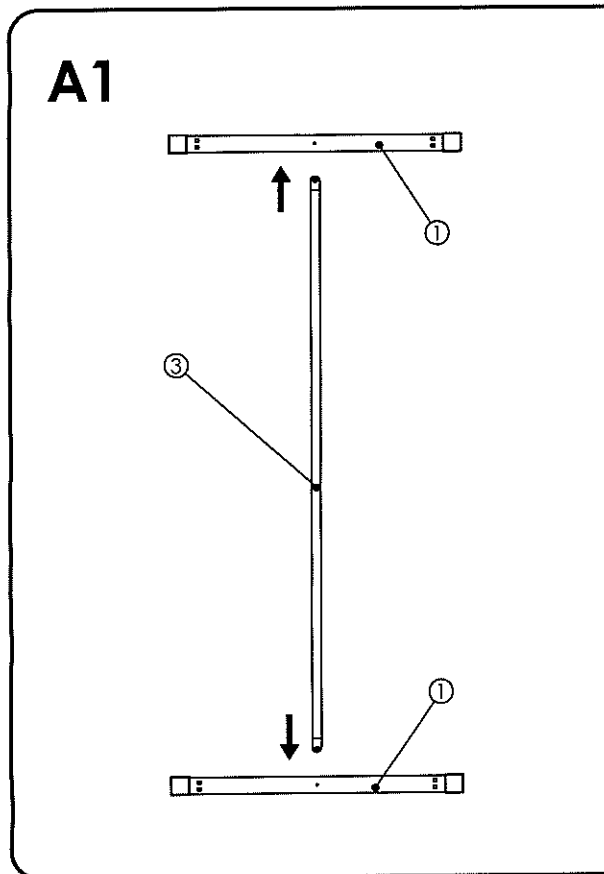
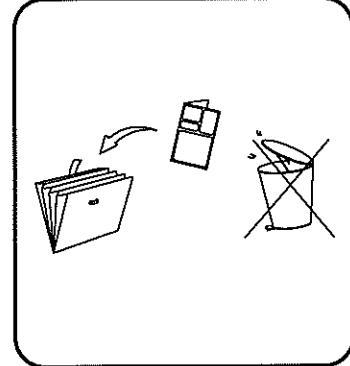
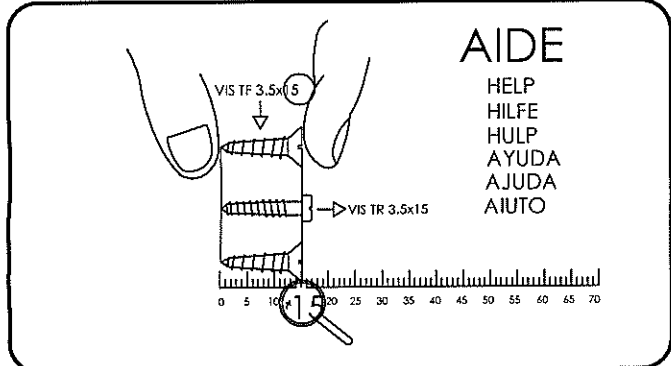

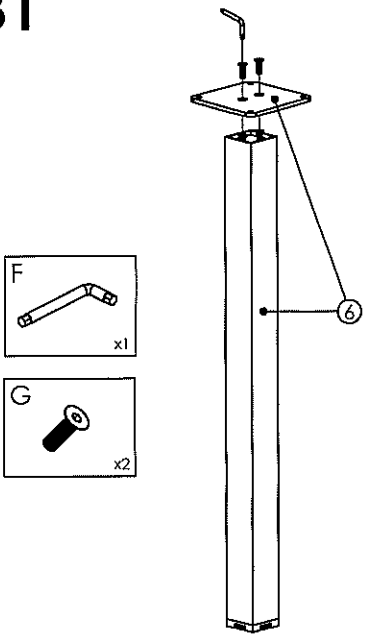
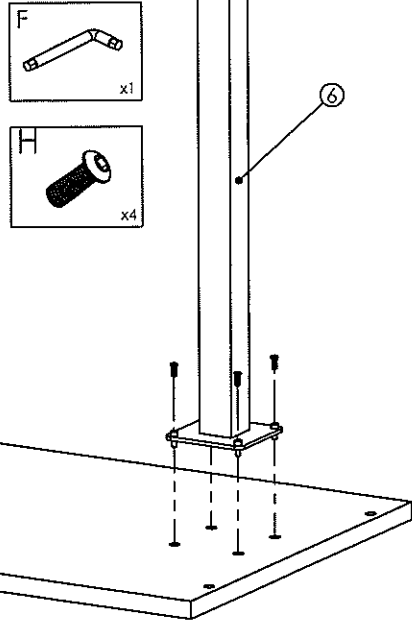
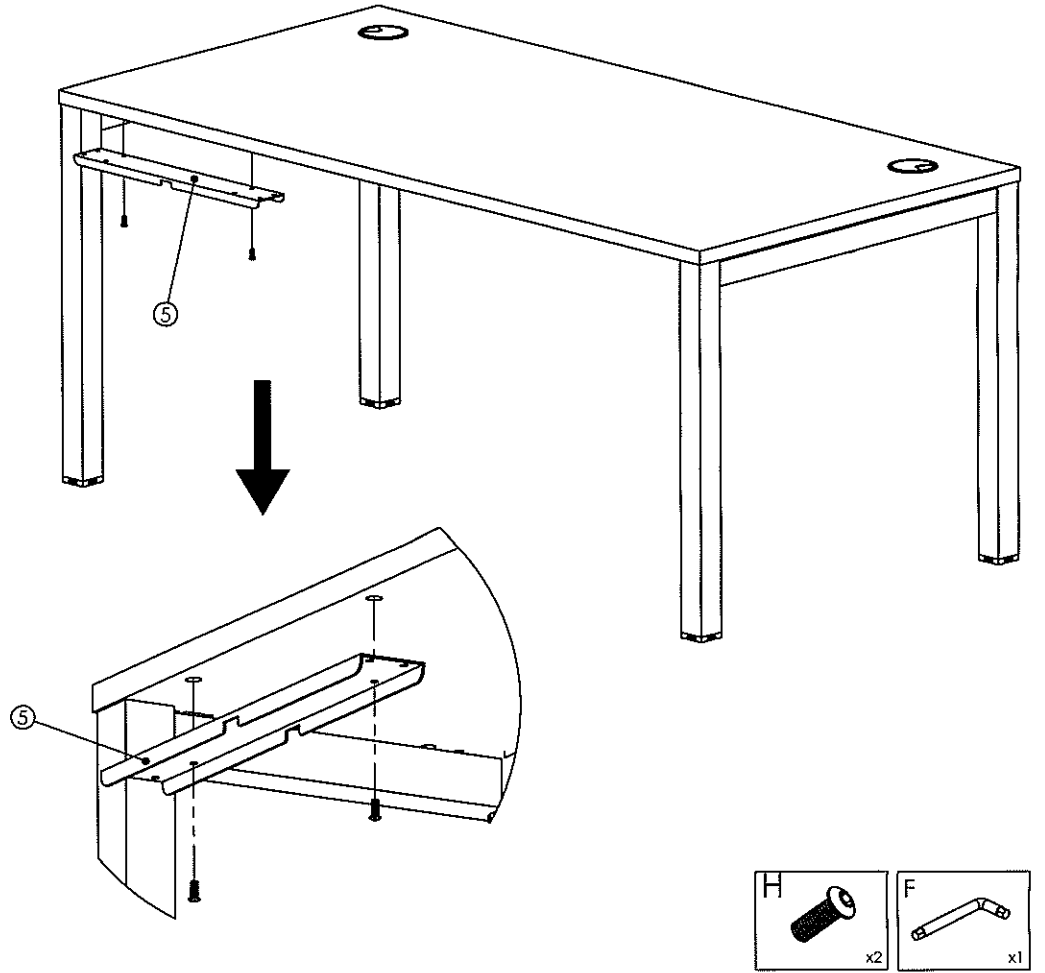
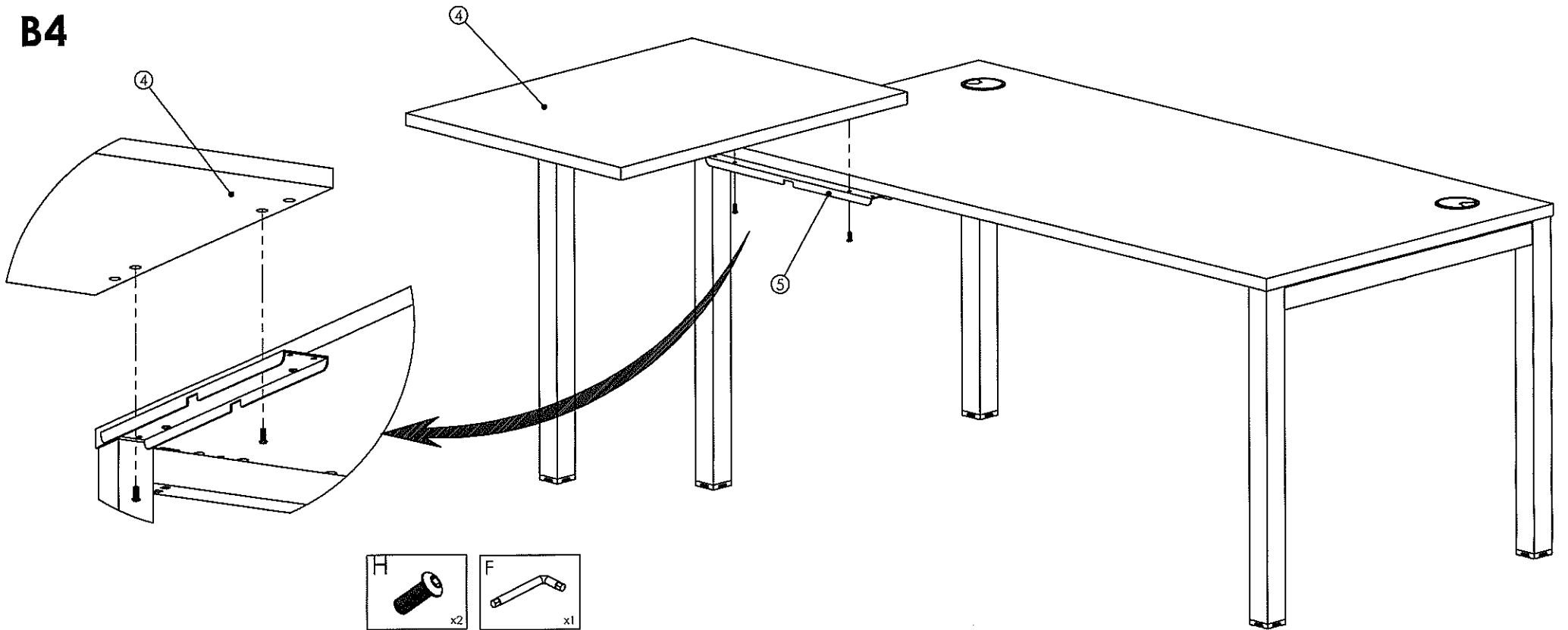
B1**B2****B3****B4****B'**

Rep.	Pièce	Qté
1	ARCHE 800	2
2	PLAN DE TRAVAIL	1
3	POUTRE	1
6	Pied 50x50	2

Rep.	Pièce	Qté
F	Clé 6 pans 5mm	1
H	VIS TCHC M6x16	2
I	Vis 4x20	6

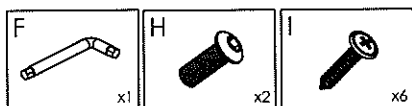
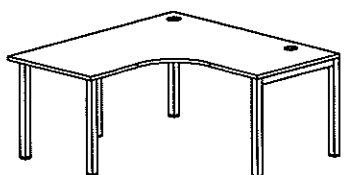
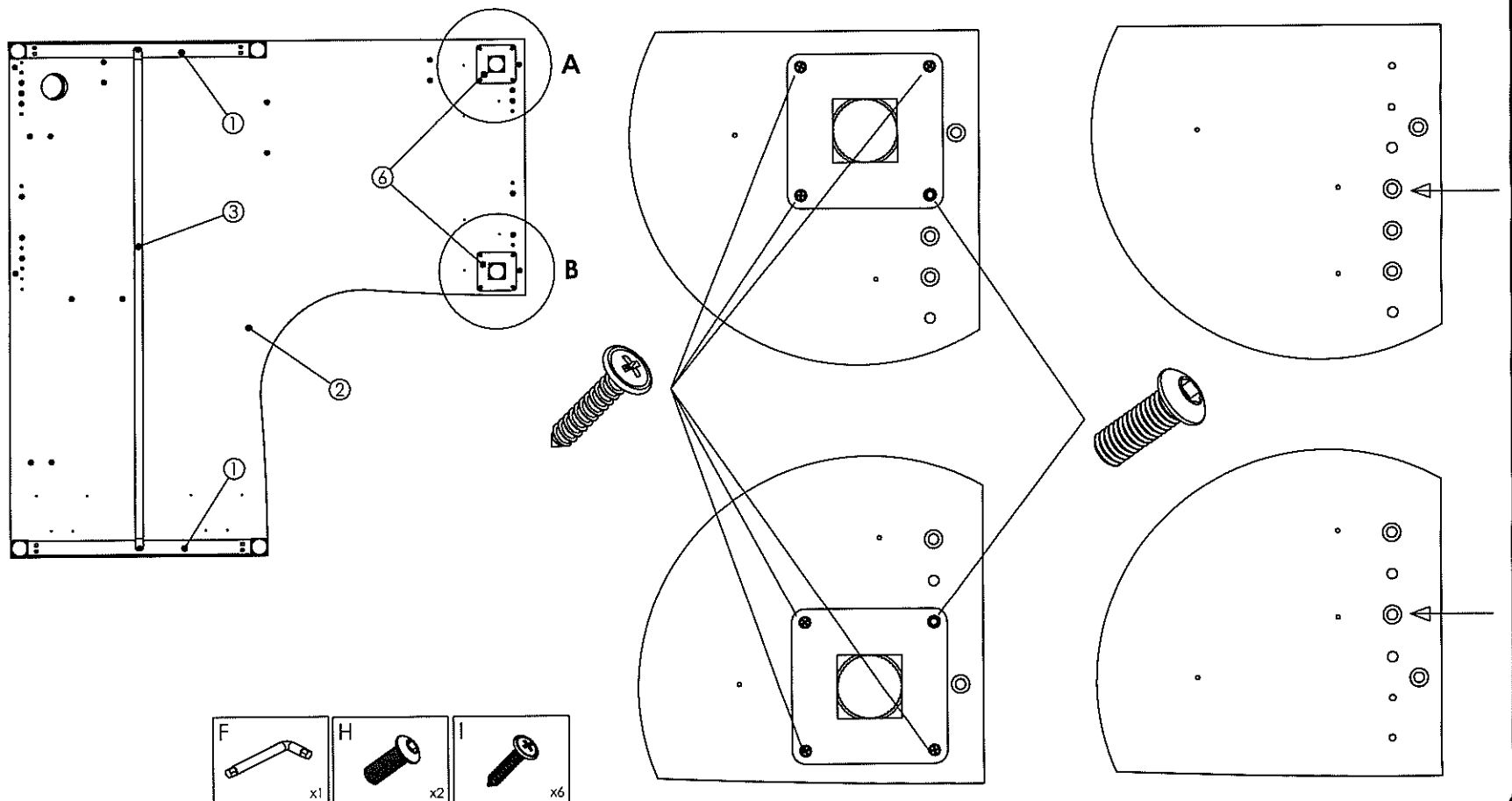

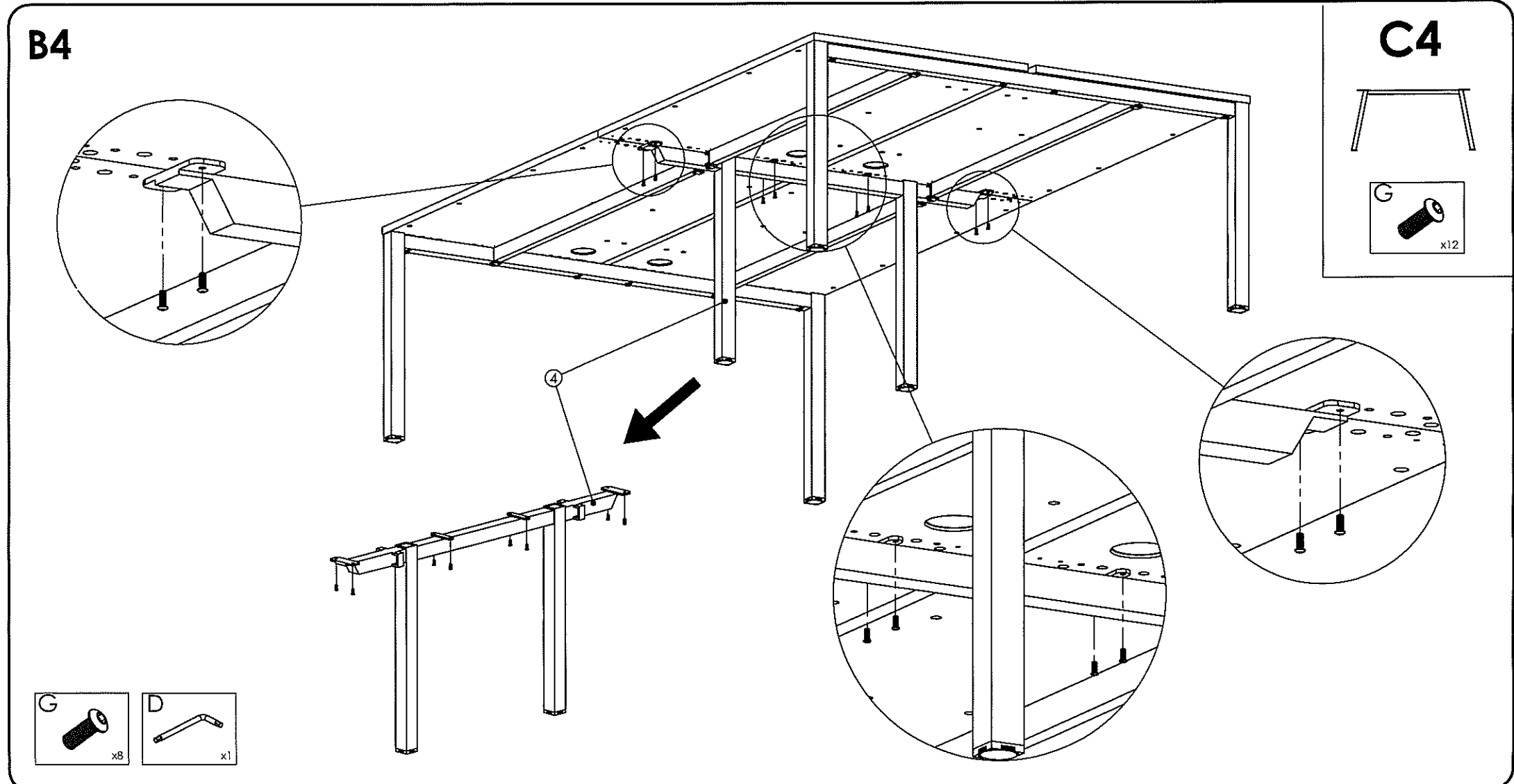
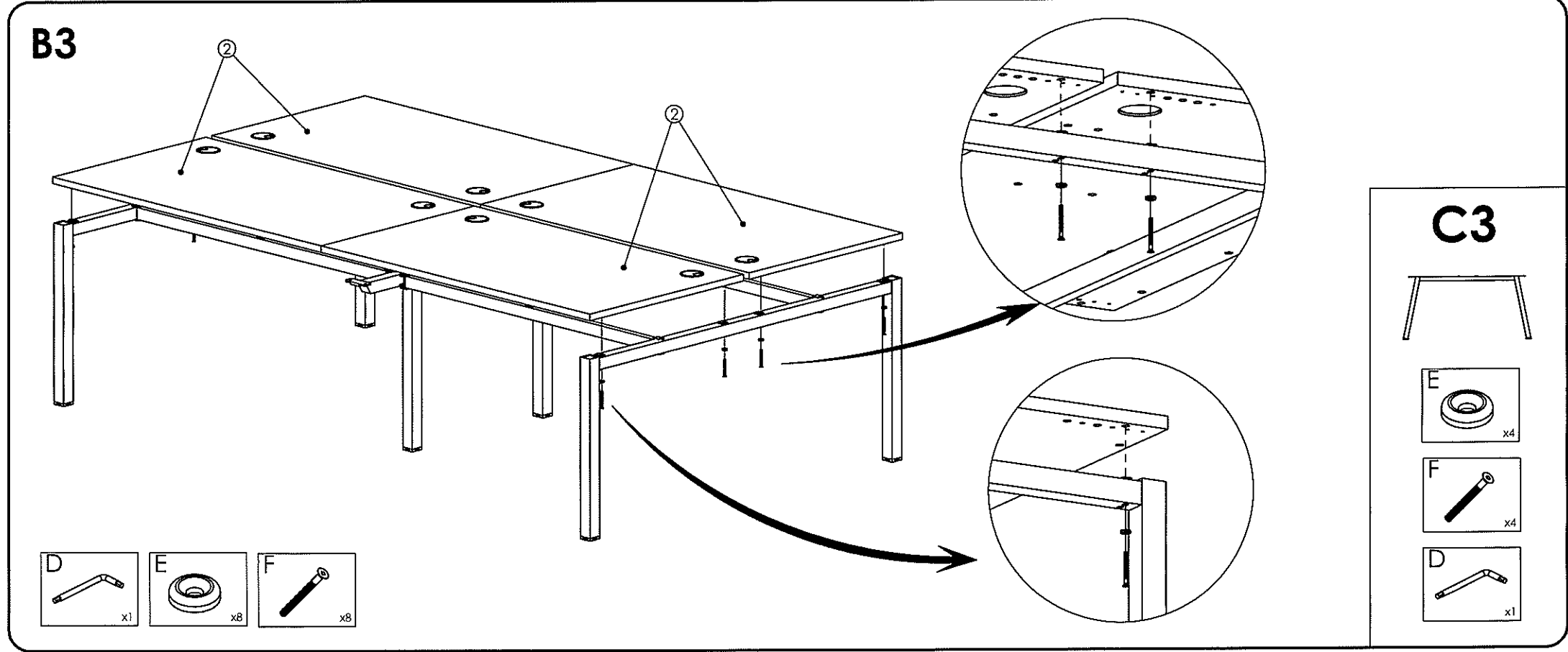
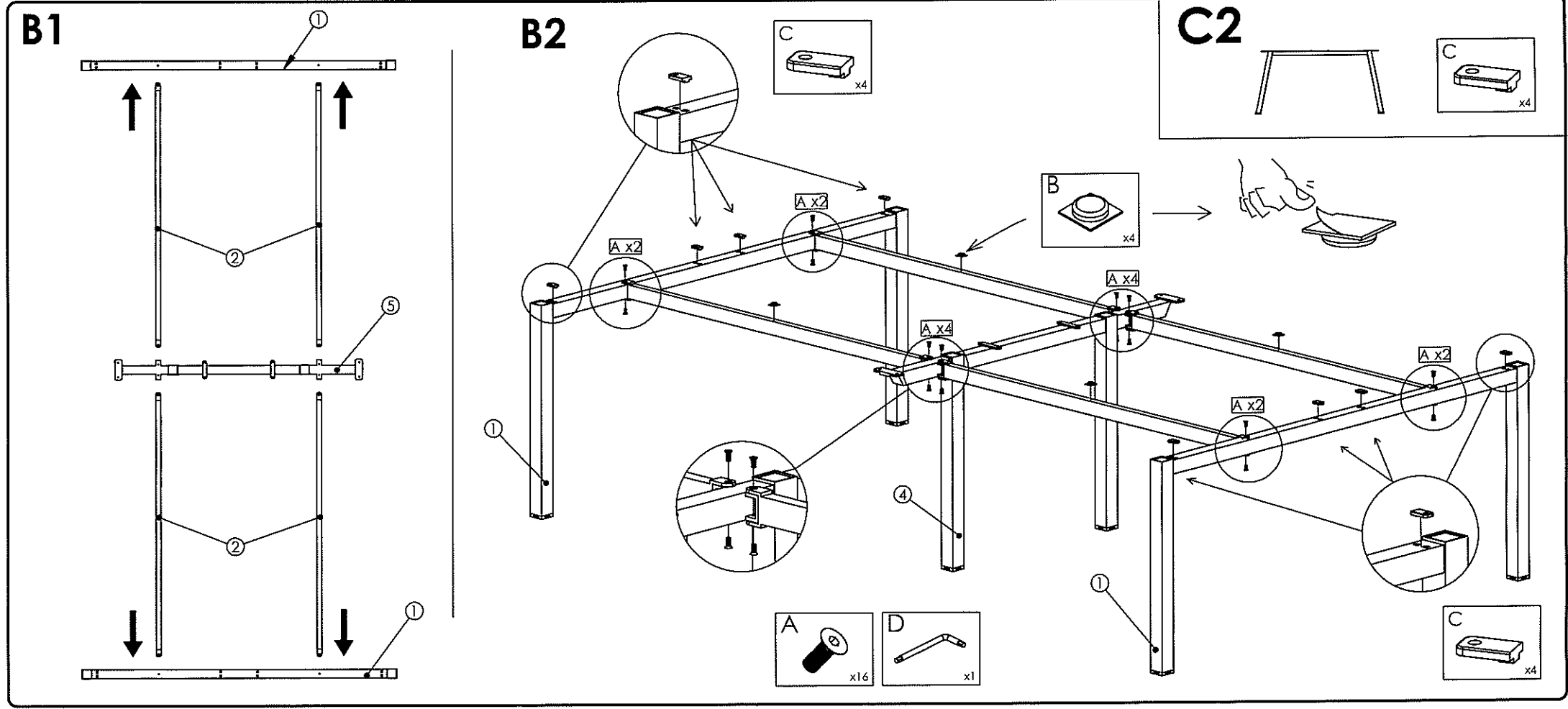

NOTICE DE MONTAGE
INSTRUCTIONS FOR ASSEMBLY
MONTAGEANLEITUNG
GEBRUIKSAANWIJZING
ISTRUZIONI DI MONTAGGIO
INSTRUCCIONES DE MONTAJE
INSTRUCCOES DE MONTAGEM

buromomic

FABRICANT FRANÇAIS

N° DV40873/01

CONCEPTION ET REALISATION BUREAU D'ETUDES BUROMOMIC

GARANTIE (vices cachés)
_ Référence produit à nous communiquer impérativement en cas de litige :
Voir étiquette apposée au dos du produit

GARANTEE (defekt)
_ In the event of complaint, it is essential to mention the product reference :
See label affixed to the back of the product.

GARANTIE (fabrikationfelher)
_ Im streitfall sit uns die produktreferenz mitzuteilen :
Siehe etikett auf produktruckseite.

WAARBORG (de verborgen gebreken)
_ Vermeld in geval van klachten altijd het productnummer :
Zie label op de achterzijde van het product

GARANZIA (vizi occulti)
_ Specificare obbligatoriamente il riferimento prodotto in caso di contestazioni :
Si veda l'etichetta applicata dietro il prodotto

GARANTIA (defectos ocultos)
_ Referencia de producto citese obligatoriamente en caso de reclamacion :
Ver etiqueta en la parte posterior del producto.

GARANTIA (vícios ocultos)
_ Em caso de reclamacao indiq-nos imperativamente a referência do produto :
Ver etiqueta fixada na parte posterior do produto

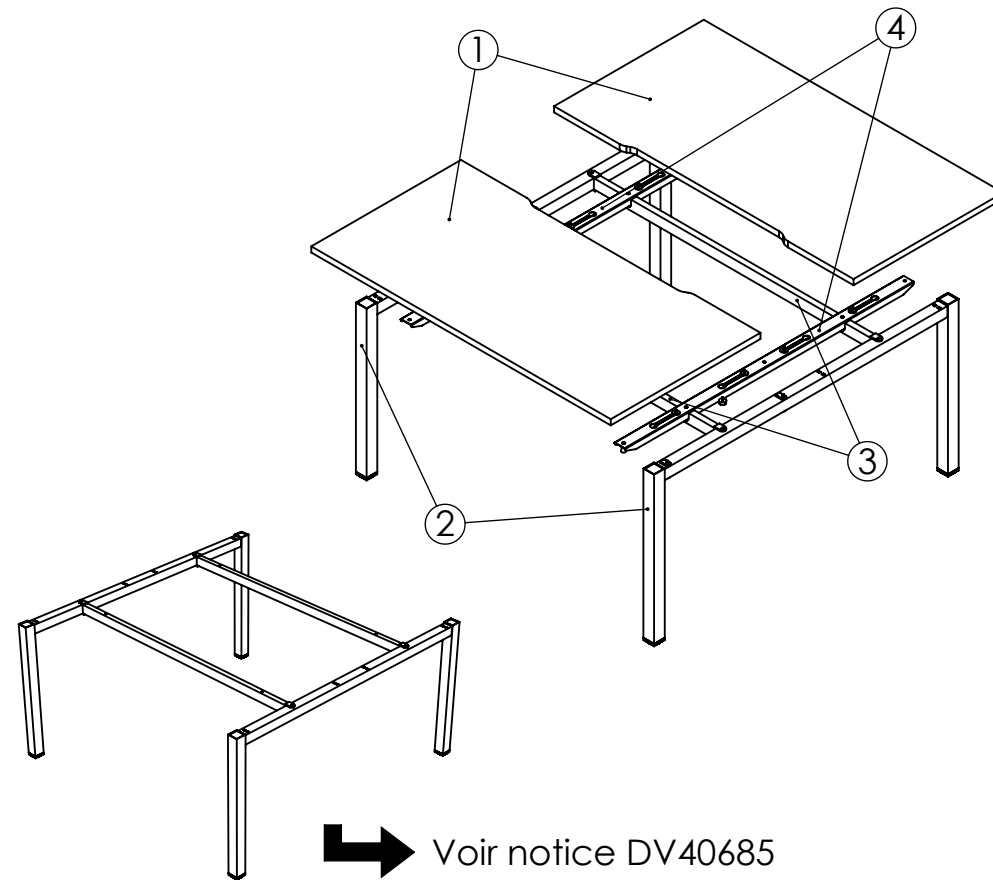
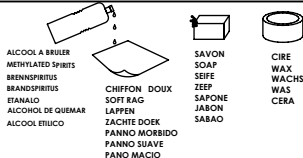
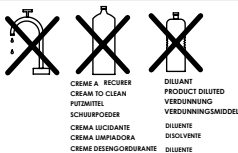
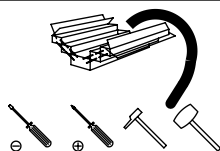
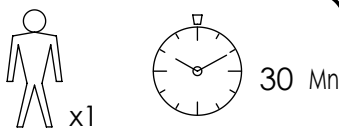
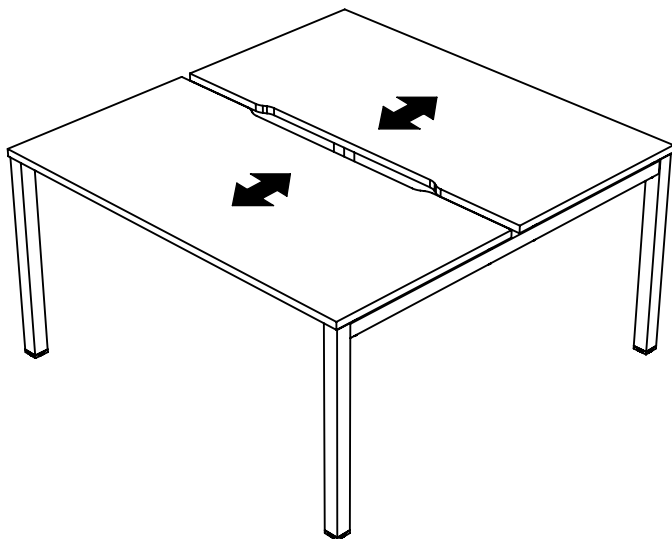

➔ Voir notice DV40685

NOMENCLATURE
(Parts list)
(Stückliste)
(Onderdelenlijst)
(Nomenclatura)
(Lista de peças)

Rep.	Pièce	Qté
1	PLAN DE TRAVAIL	2
2	ARCHE	2
3	POUTRE 140	2
4	RAIL COULISSANT	2

QUINCAILLERIE

Rep.	Pièce	Qté	A	B	C
B	VIS TBHc M6x50	4			
C	PLOT RAIL COULISSANT	8			
D	Vis TFHc M6x20	8			
E	Vis SThc M8x6	4			
F	Butée	4			
G	Vis TCB 4x20	4			
H	Clé 6 pans 4mm	4			
			K	L	M

(Hardware)
(Beschiège)
(Ijzerwaren)
(Ferramenta)
(Herrajes)
(Quinquilharia)

AIDE

HELP
HILFE
HULP
AYUDA
AJUDA
AIUTO

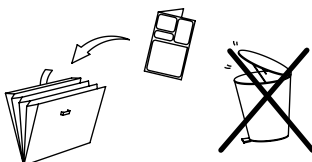
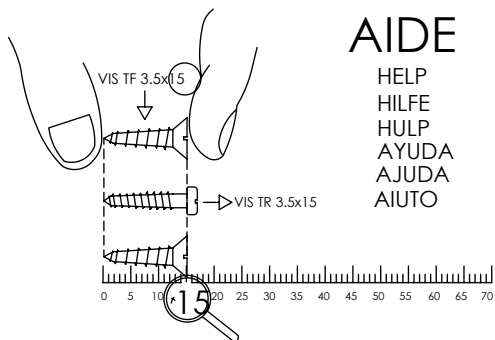

NOTICE DE MONTAGE
INSTRUCTIONS FOR ASSEMBLY
MONTAGEANLEITUNG
GEBRUIKSAANWIJZING
ISTRUZIONI DI MONTAGGIO
INSTRUCCIONES DE MONTAJE
INSTRUCCOES DE MONTAGEM

buronomic

FABRICANT FRANÇAIS

N° DV40875

CONCEPTION ET REALISATION BUREAU D'ETUDES BURONOMIC

GARANTIE (vices cachés)
_ Référence produit à nous communiquer impérativement en cas de litige :
Voir étiquette apposée au dos du produit

GARANTEE (defekt)
_ In the event of complaint, it is essential to mention the product reference :
See label affixed to the back of the product.

GARANTIE (fabrikationfelhar)
_ Im streitfall sit uns die produktreferenz mitzuteilen :
Siehe etiket auf produktruckseite.

WAARBORG (de verborgen gebreken)
_ Vermeld in geval van klachten altijd het productnummer :
Zie label op de achterzijde van het product

GARANZIA (vizi occulti)
_ Specificare obbligatoriamente il riferimento prodotto in caso di contestazioni :
Si veda l'etichetta applicata dietro il prodotto

GARANTIA (defectos ocultos)
_ Referencia de producto citese obligatoriamente en caso de reclamacion :
Ver etiqueta en la parte posterior del producto.

GARANTIA (vicios ocultos)
_ Em caso de reclamacao indiqu-nos imperativamente a referencia do produto :
Ver etiqueta fixada na parte posterior do produto

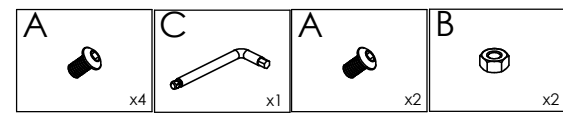
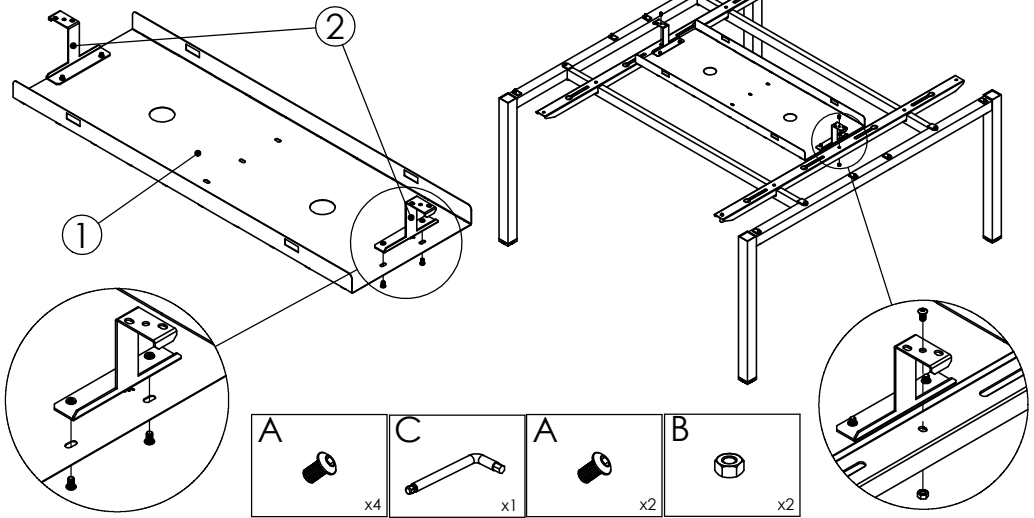
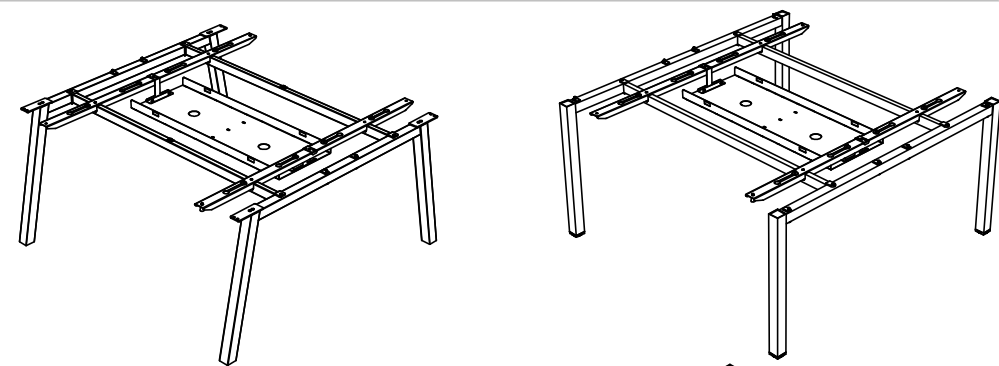

10 Mn

x1

CREAM A. RECHNER
CREAM TO CLEAN
PUTZMITTEL
SCHWUPFPOEDER
CREMA LUCIDANTE
CREMA DESENGORDURANTE
DILUENTE

DISANT
PRODUCT DILUTED
VERDUNNING
VERDUNNINGSMIDDEL
DILUENTE

ALCOOL A BRUIER
METHYLATED SPIRITS
BRANDSPIRITUS
ETANALO
ALCOHOL DE QUEMAR
ALCOOL ETIRICO

CHIFFON DOUX
SOFT RAG
LAPPEN
ZACHTE DOEK
PANNO MORBIDO
PANO SUAVE
PANO MACIO

SAVON
SOAP
SEIFE
ZEEP
SAPONE
JABON
SABAO

CIRE WAX
WACHS
WAS
CERA

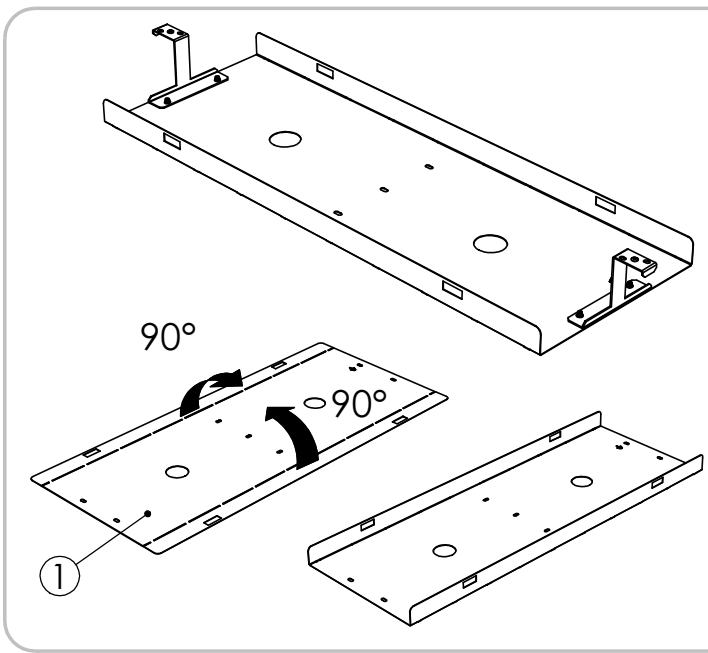

NOMENCLATURE
(Parts list)
(Stückliste)
(Onderdelenlijst)
(Nomenclatura)
(Lista de peças)

Rep.	Pièce	Qté
1	Bac tôle à plat	1
2	PATTE de FIXATION	2

QUINCAILLERIE
(Hardware)
(Beschiège)
(Ijzerwaren)
(Ferramentas)
(Herrajes)
(Quinquilharía)

Rep.	Pièce	Qté	A	B	C
A	VIS TBHc M6x10	6			
B	ECROU M6	2	D	E	F
C	Clé 6 pans 4mm	1	G	H	I
			K	L	M

AIDE
HELP
HILFE
HULP
AYUDA
AJUDA
AIUTO

VIS TF 3.5x(5)
VIS TR 3.5x15

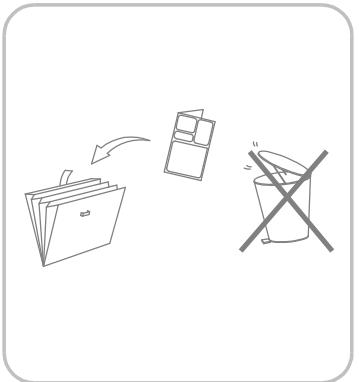

NOTICE DE MONTAGE
INSTRUCTIONS FOR ASSEMBLY
MONTAGEANLEITUNG
GEBRUIKSAANWIJZING
ISTRUZIONI DI MONTAGGIO
INSTRUCCIONES DE MONTAJE
INSTRUCCOES DE MONTAGEM

buronomic
FABRICANT FRANÇAIS

N° DV40927

CONCEPTION ET REALISATION BUREAU D'ETUDES BURONOMIC

GARANTIE (vices cachés)
_ Référence produit à nous communiquer impérativement en cas de litige :
Voir étiquette apposée au dos du produit

GARANTIE (defekt)
_ In the event of complaint, it is essential to mention the product reference :
See label affixed to the back of the product.

GARANTIE (fabrikationfehler)
_ Im streifall sit uns die produktreferenz mitzuteilen :
Siehe etikett auf produckruckseite.

WAARBORG (de verborgen gebreken)
_ Vermeld in geval van klachten altijd het productnummer :
Zie label op de achterzijde van het product

GARANZIA (vizi oculte)
_ Specificare obbligatoriamente il riferimento prodotto in caso di contestazioni :
Si veda l'etichetta applicata dietro il prodotto

GARANTIA (defectos ocultos)
_ Referencia de producto citese obligatoriamente en caso de reclamacion :
Ver etiqueta en la parte posterior del producto.

GARANTIA (vices ocultas)
_ Em caso de reclamacao indiqu-nos imperativamente a referencia do produto :
Ver etiqueta fixada na parte posterior do produto

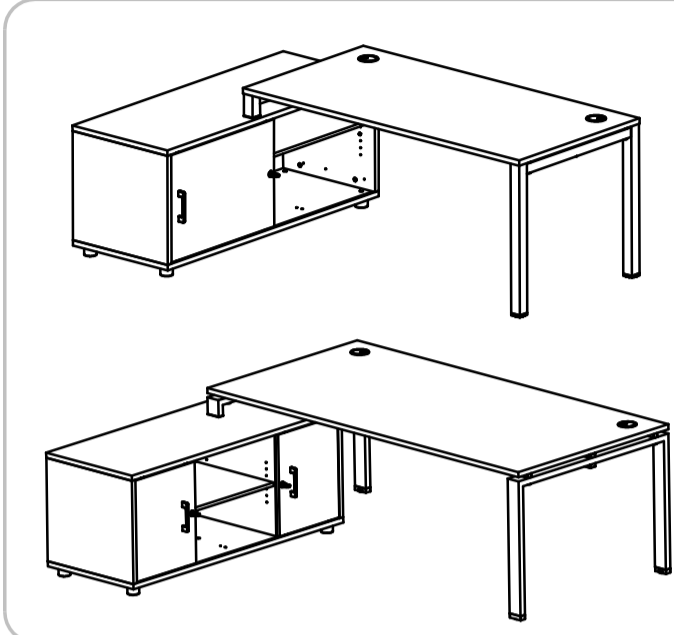
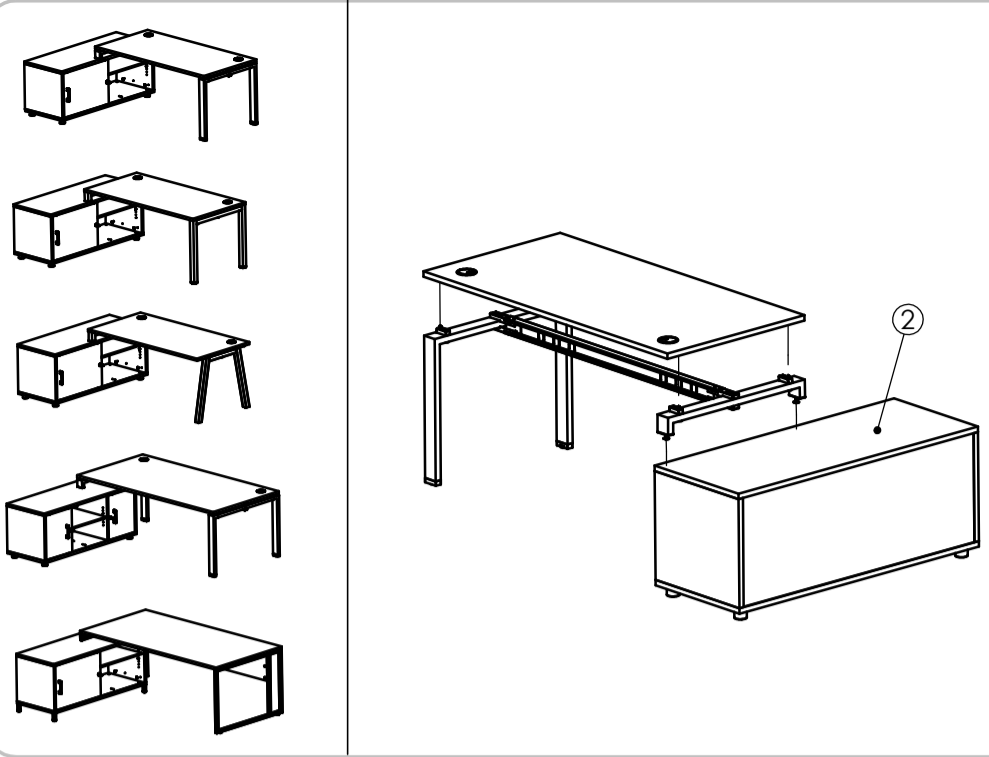

x1 10 Mn

CHIFFON DOUX
SOFT RAG
LAPPEN
ZACHTE DOEK
FANNO MORBIDO
FANNO SUAVE
FANNO MACIO

SAYON SOAP
SEIFE
SAPONE
JABON
SABAO

CIRE WAX
WACHS
WAS
CERA

NOMENCLATURE (Parts list)
(Stückliste)
(Onderdelenlijst)
(Nomenclatura)
(Lista de peças)

Rep.	Pièce	Qté
2	DESSUS	1

QUINCAILLERIE (Hardware)
(Beschläge)
(Izerwaren)
(Ferramentas)
(Quinquilharia)

	A	B	C
	D	E	F
	G	H	I
	J	K	L
	M	N	O
	P	Q	R

AIDE
HELP
HILFE
HULP
AYUDA
AJUDA
AIUTO

VIS TF 3.5x15
VIS TR 3.5x15

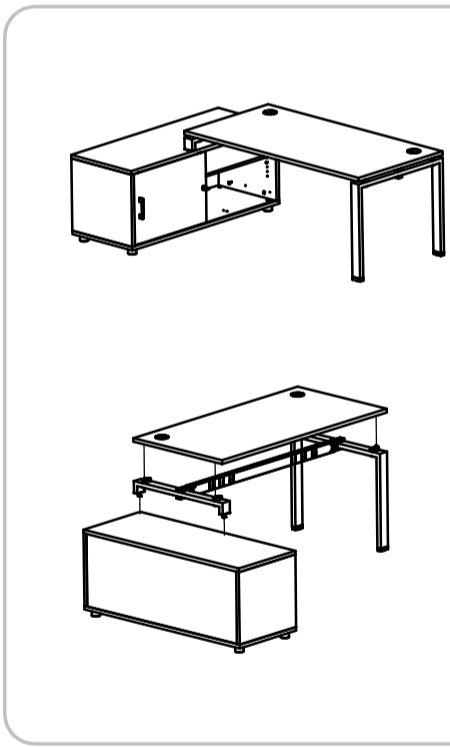
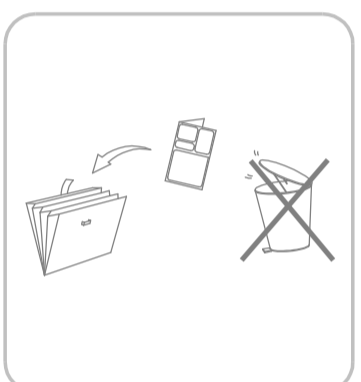

Retour gauche

Retour droit

Rep.	Pièce	Qté
A	Arche 100 1 pied court	1
B	Entretoise	4
C	Rondelle plate	4
D	Vis TFHC M6x65	4
E	Mousse	1
F	Rondelle	1
G	VIS TBHc M6x40	1
H	Clé 6 pans 4mm	2

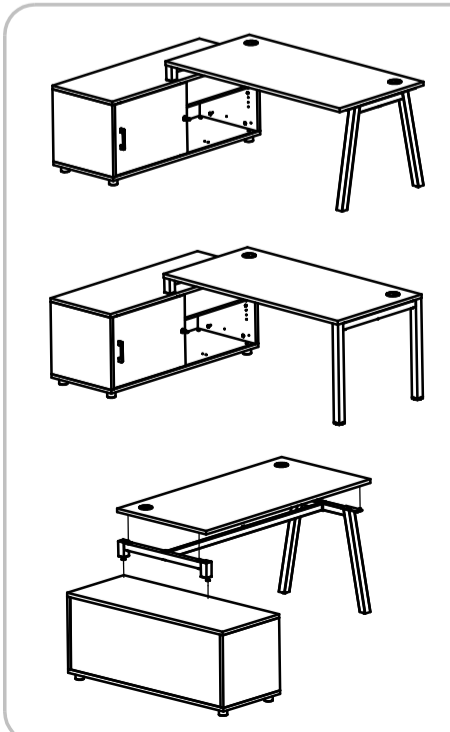

Retour gauche

Retour droit

Rep.	Pièce	Qté
A	ARCHE 800 recoupé	1
B	Entretoise plastique	4
C	Rondelle A1	4
D	Vis TFHC M6x65	4
E	Mousse 52x52	2
F	VIS TBHc M6x40	2
G	Rondelle	2
H	Clé 6 pans 4mm	2

Rep.	Pièce	Qté
A	Arche 100 1 pied court	1
B	Entretoise	4
C	Rondelle plate	4
D	Vis TFHC M6x65	4
E	Mousse	1
F	Rondelle	1
G	VIS TBHc M6x40	1
H	Clé 6 pans 4mm	2

Rep.	Pièce	Qté
A	Arche 100 1 pied court	1
B	Entretoise	4
C	Rondelle plate	4
D	Vis TFHC M6x65	4
E	Mousse	1
F	Rondelle	1
G	VIS TBHc M6x40	1
H	Clé 6 pans 4mm	2

Rep.	Pièce	Qté
A	PIED de RETOUR cabinet	1
B	VIS TBHc M8x35	2

NOTICE DE MONTAGE
INSTRUCTIONS FOR ASSEMBLY
MONTAGEANLEITUNG
GEBRUIKSAANWIJZING
ISTRUZIONI DI MONTAGGIO
INSTRUCCIONES DE MONTAJE
INSTRUÇÕES DE MONTAGEM

buronomic
FABRICANT FRANÇAIS

N° DV40925

CONCEPTION ET REALISATION BUREAU D'ETUDES BURONOMIC

GARANTIE (vices cachés)
_ Référence produit à nous communiquer impérativement en cas de litige :
Voir étiquette apposée au dos du produit

GARANTIE (defekt)
_ In the event of complaint, it is essential to mention the product reference :
See label affixed to the back of the product.

GARANTIE (fabrikationsfeil)
_ Im streitfall sit uns die produktreferenz mitzuteilen :
Siehe etikett auf produktdruckseite.

WAARBORG (de verborgen gebreken)
_ Vermeld in geval van klachten altijd het productnummer :
Zie label op de achterzijde van het product

GARANZIA (vizi occulti)
_ Specificare obbligatoriamente il riferimento prodotto in caso di contestazioni :
Si veda l'etichetta applicata dietro il prodotto

GARANTIA (defectos ocultos)
_ Referencia de producto citese obligatoriamente en caso de reclamacion :
Ver etiqueta en la parte posterior del producto.

GARANTIA (vices ocultas)
_ Em caso de reclamacao indiqu-nos imperativamente a referencia do produto :
Ver etiqueta fixada na parte posterior do produto

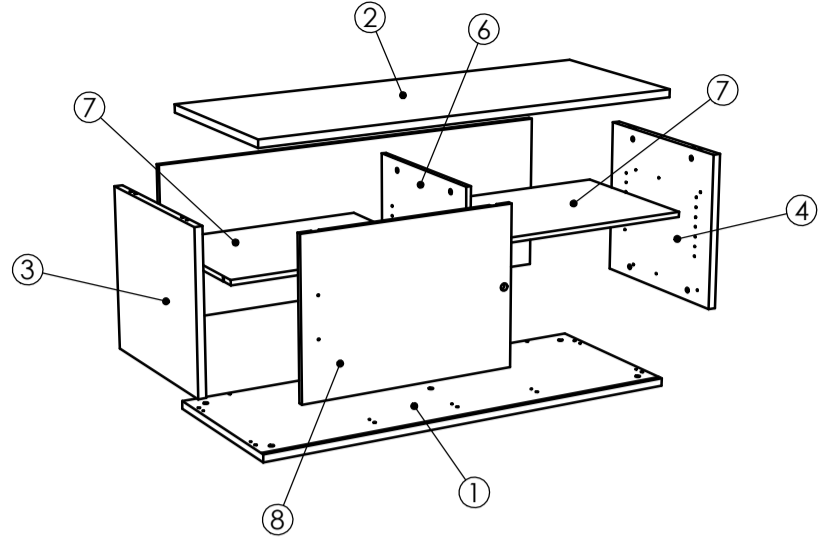

Ga

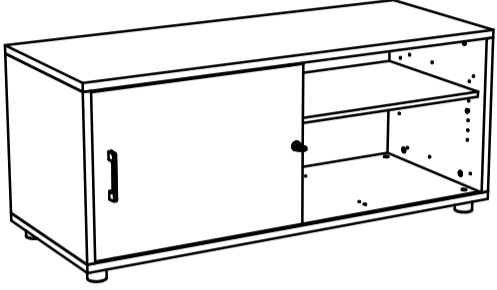

Dr

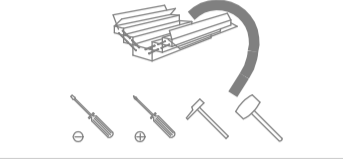
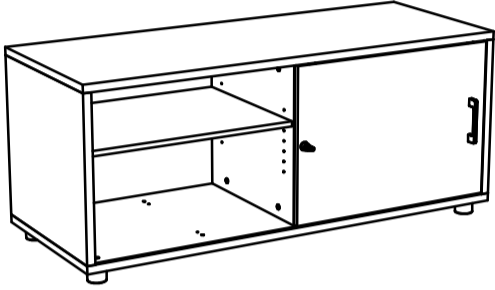

NOMENCLATURE

(Parts list)
(Stückliste)
(Onderdelenlijst)
(Nomenclatura)
(Lista de peças)

Rep.	Pièce	Qté
1	FOND	1
2	DESSUS	1
3	Coté Ga	1
4	Coté Dr	1
5	PAR	1
6	SEPARATION	1
7	TABLETTE	2
8	PORTE	1

QUINCAILLERIE

(Hardware)
(Beschläge)
(Ijzerwaren)
(Ferramenta)
(Herrajes)
(Quinquilharia)

Rep.	Pièce	Qté	A	B	C	D	E	F	G	H	I	J	K	L	M	N	O	P	Q	R
A	Goujon bois	12																		
B	Excentrique court	12																		
C	Patin Ht 43	5																		
D	Vis TF 3,5x15	1																		
E	Vis exp.	4																		
F	Serrure poussoir	1																		
G	Vis TF 3x15	2																		
H	Poignée design entraxe 128	1																		
I	Vis TRL 4x22	2																		
J	Cache excent.	12																		
K	Cache Ø8	4																		
L	Cache Ø15	5																		
M	Guide rail Bas	2																		
N	Guide rail Haut	2																		
O																				

AIDE

HELP
HILFE
HULP
AYUDA
AJUDA
AIUTO

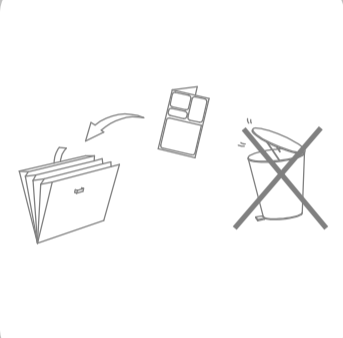
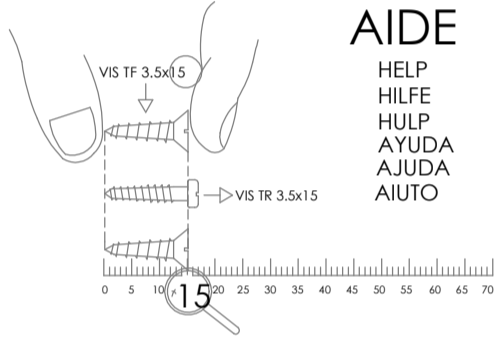

1

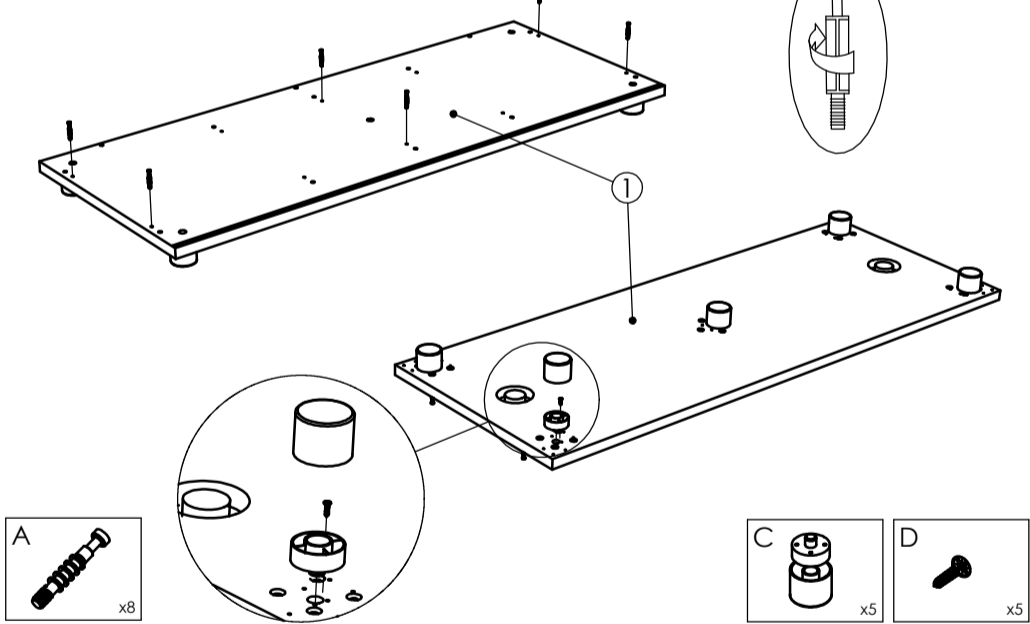

2

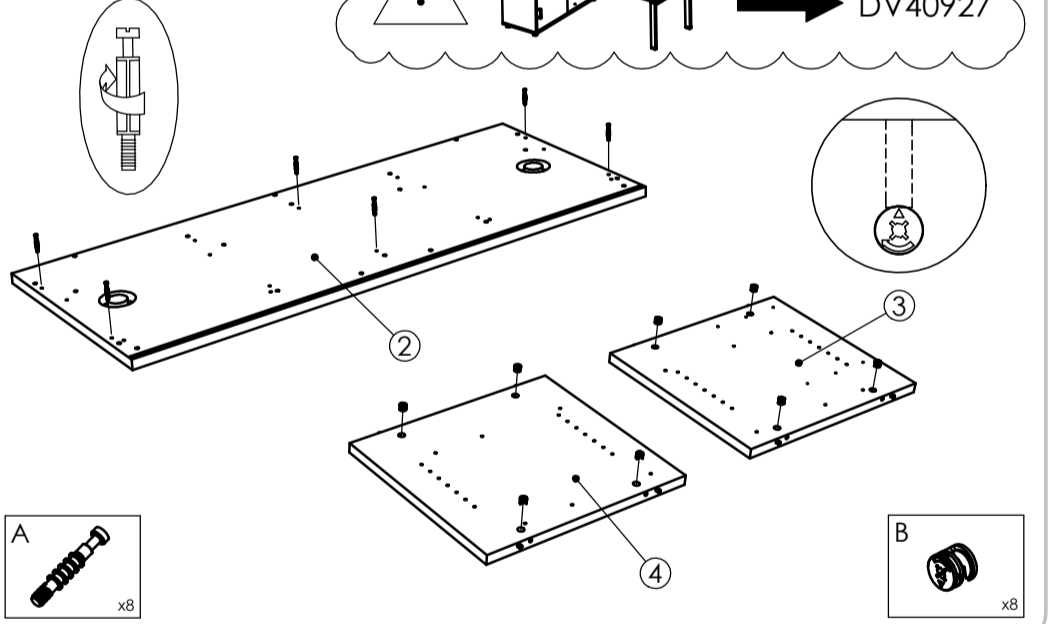

3

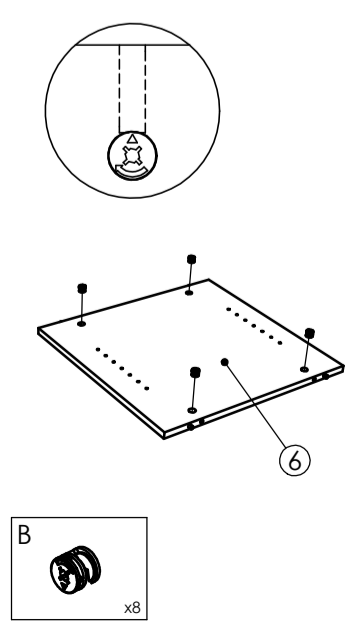

4

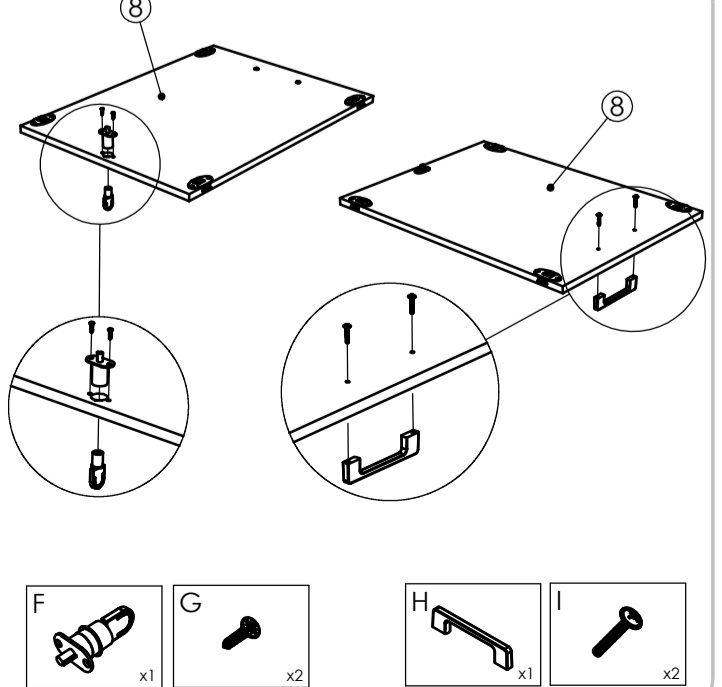
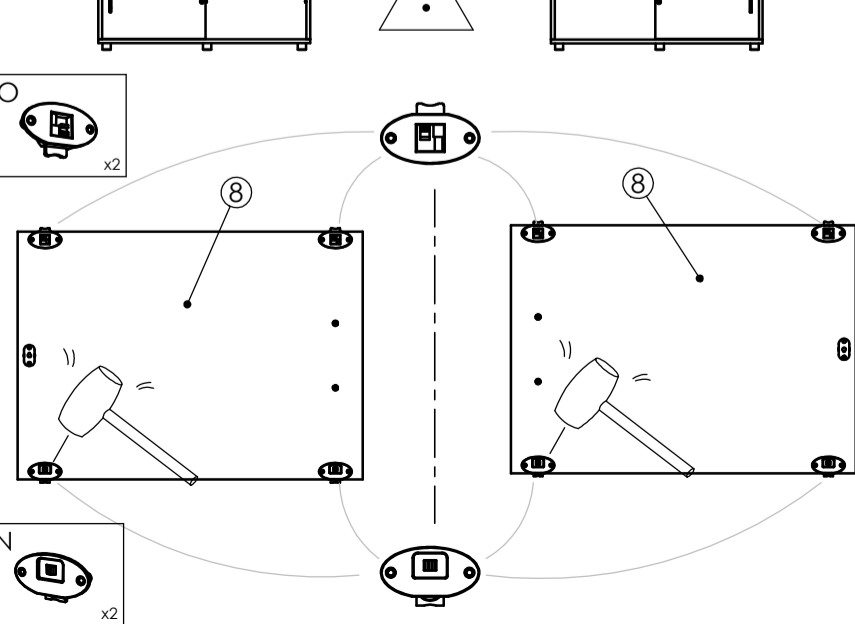

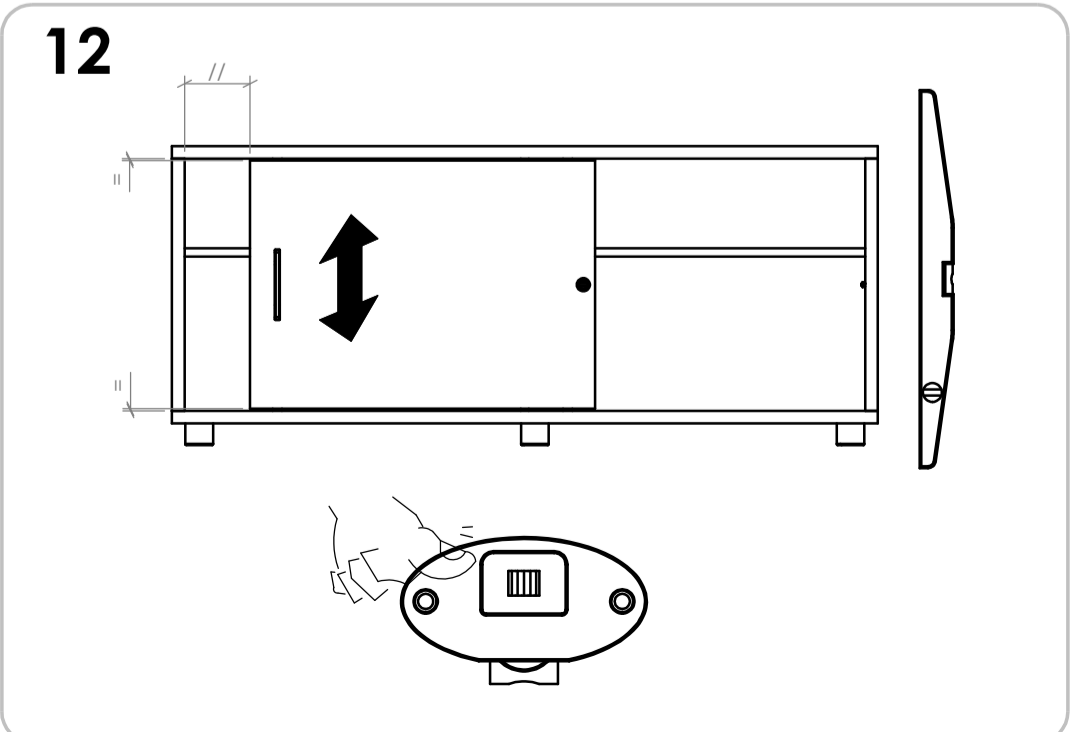
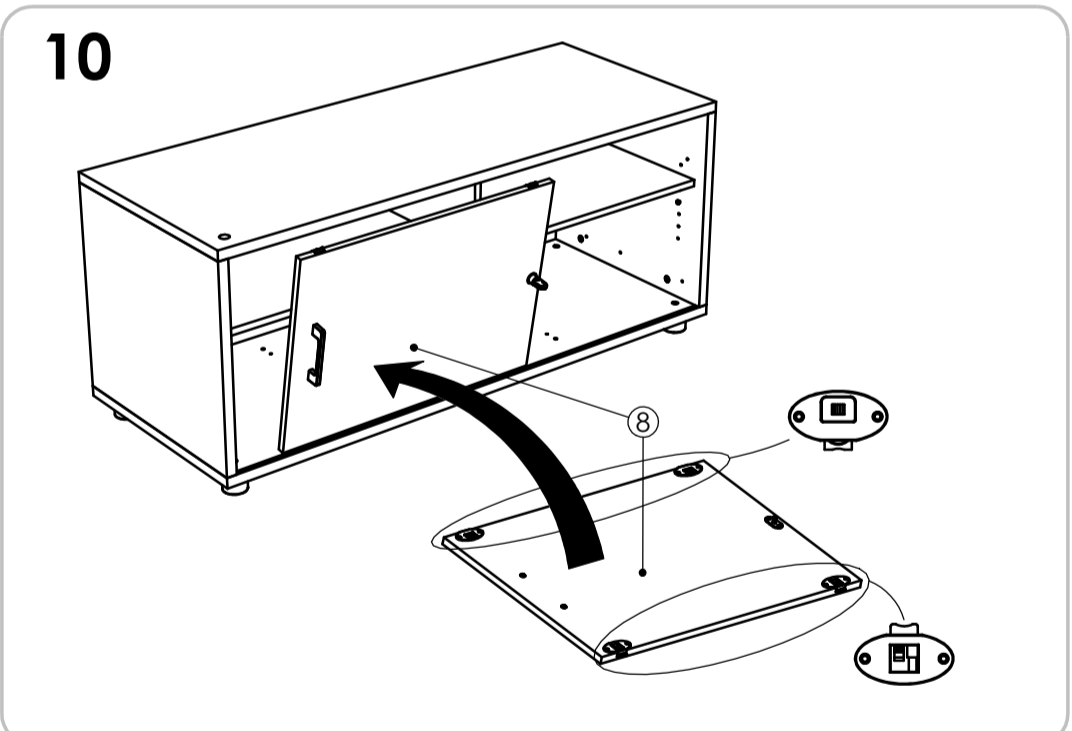
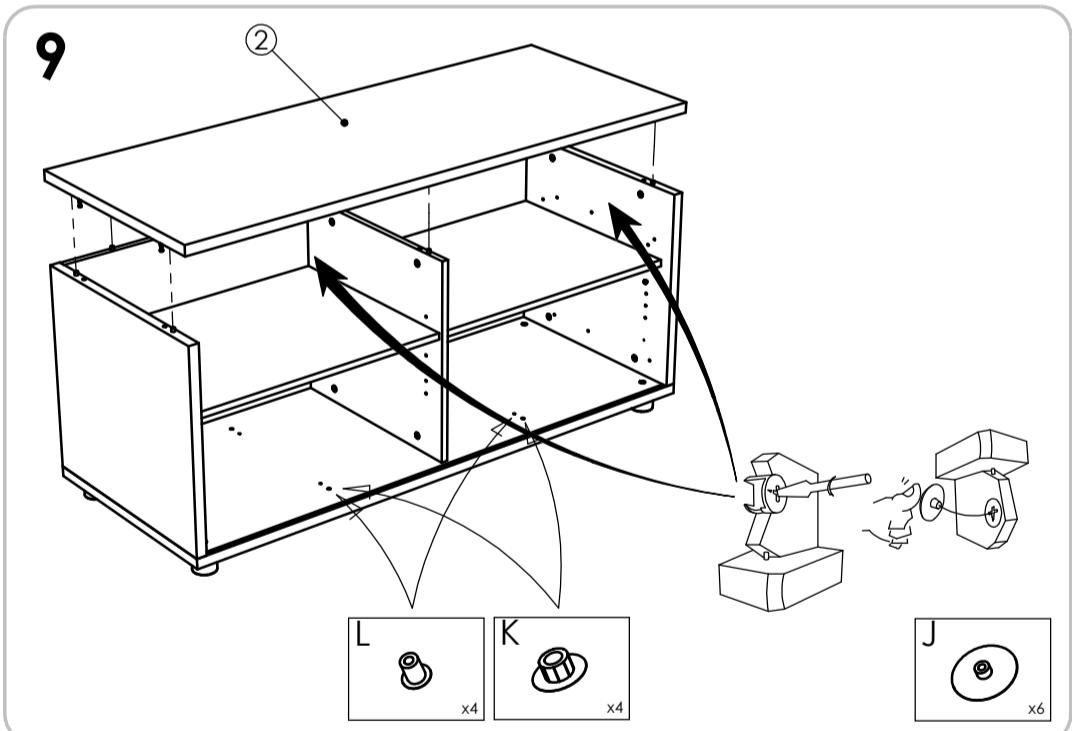
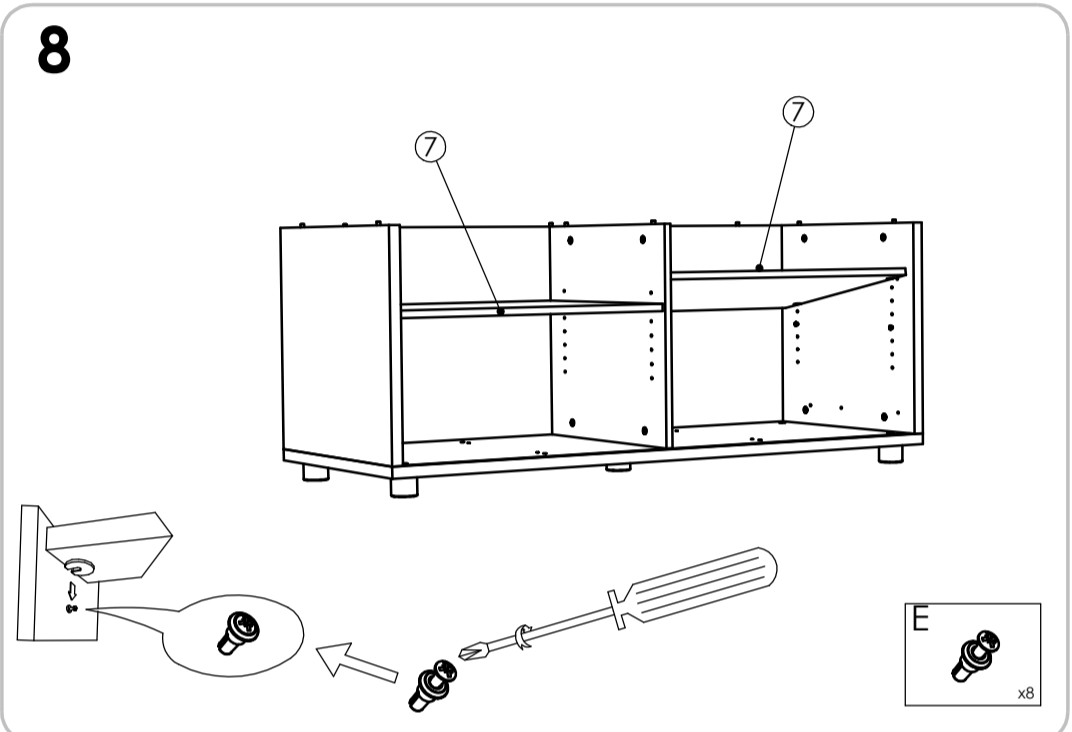
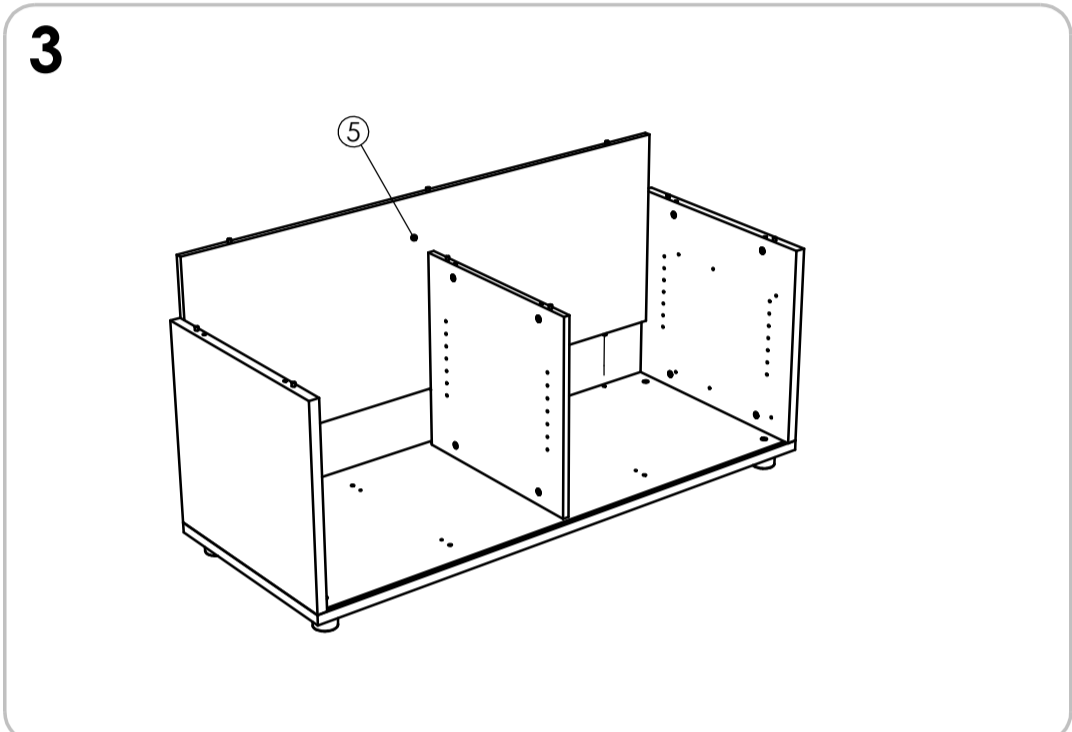
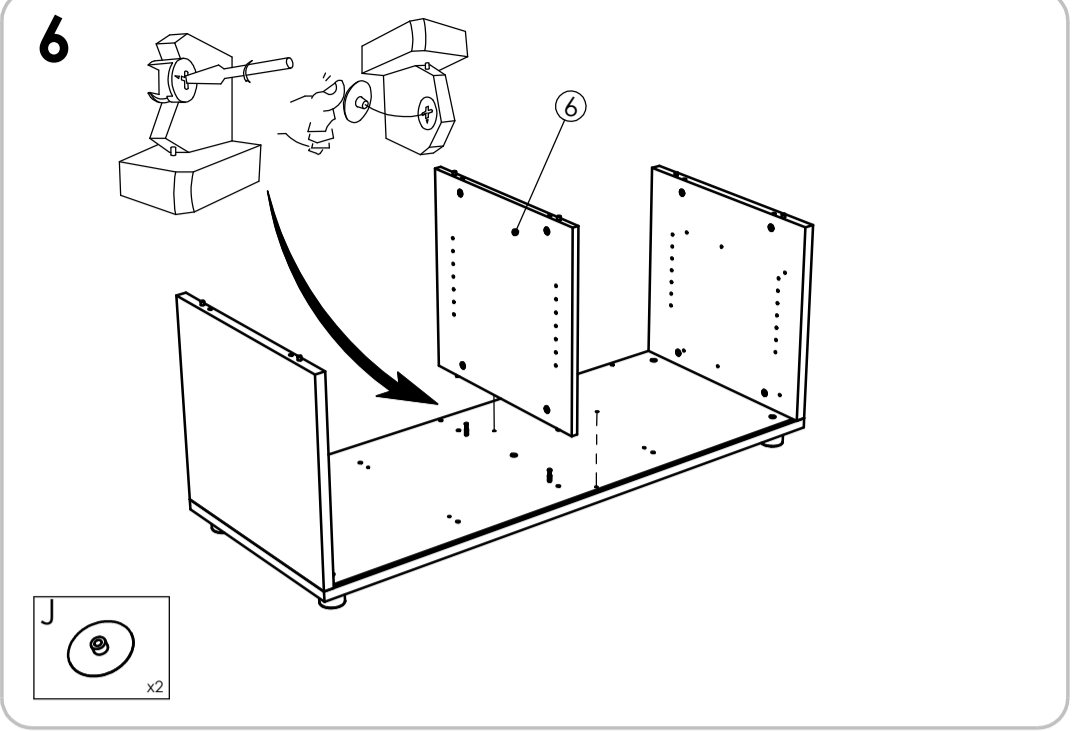
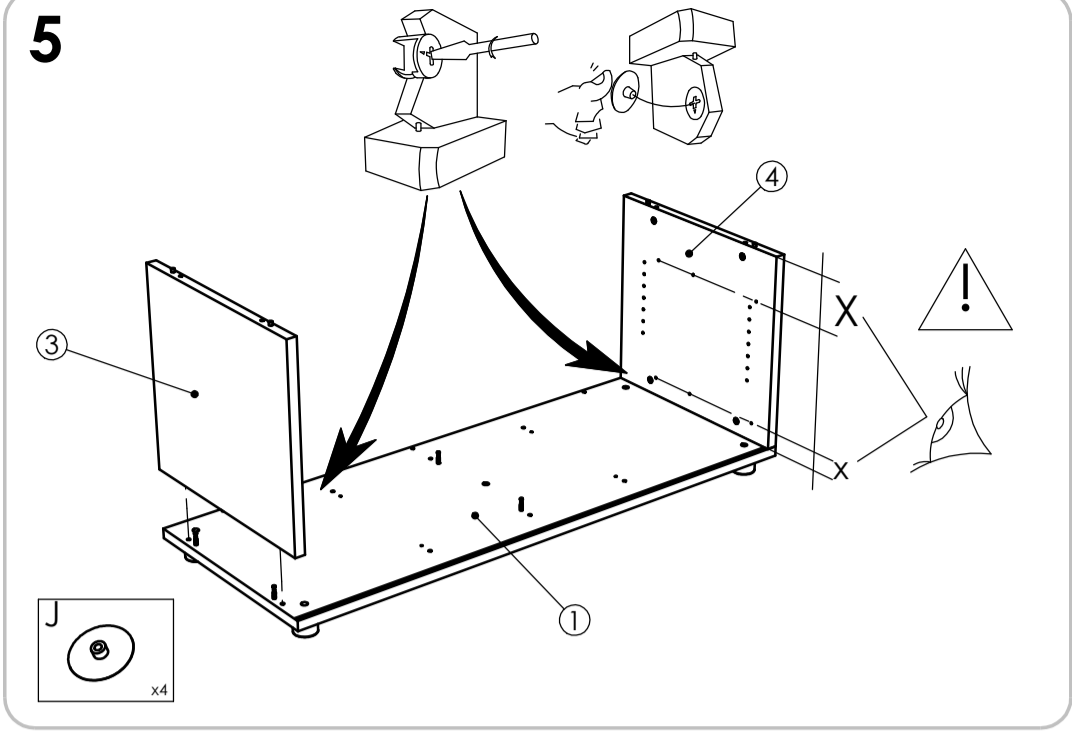

NOTICE DE MONTAGE
INSTRUCTIONS FOR ASSEMBLY
MONTAGEANLEITUNG
GEBRUIKSAANWIJZING
ISTRUZIONI DI MONTAGGIO
INSTRUCCIONES DE MONTAJE
INSTRUCCOES DE MONTAGEM

buronomic

FABRICANT FRANÇAIS

N° DV40929

CONCEPTION ET REALISATION BUREAU D'ETUDES BURONOMIC

GARANTIE (vices cachés)
_ Référence produit à nous communiquer impérativement en cas de litige :
Voir étiquette apposée au dos du produit

GARANTEE (defekt)
_ In the event of complaint, it is essential to mention the product reference :
See label affixed to the back of the product.

GARANTIE (fabrikationfelhar)
_ Im streifall sit uns die produktreferenz mitzuteilen :
Siehe etikett auf produktruckseite.

WAARBORG (de verborgen gebreken)
_ Vermeld in geval van klachten altijd het productnummer :
Zie label op de achterzijde van het product

GARANZIA (vizi occulti)
_ Specificare obbligatoriamente il riferimento prodotto in caso di contestazioni :
Si veda l'etichetta applicata dietro il prodotto

GARANTIA (defectos ocultos)
_ Referencia de producto citese obligatoriamente en caso de reclamacion :
Ver etiqueta en la parte posterior del producto.

GARANTIA (vicios ocultos)
_ Em caso de reclamacao indiqu-nos imperativamente a referencia do produto :
Ver etiqueta fixada na parte posterior do produto

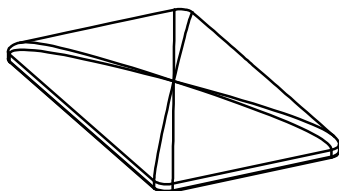
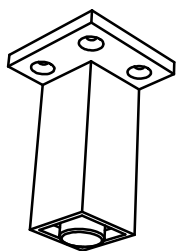
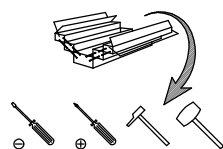
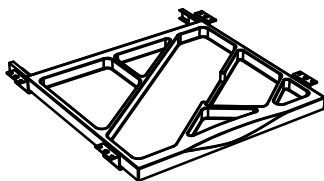
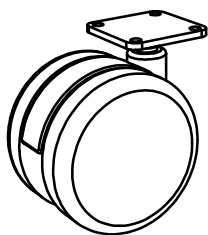
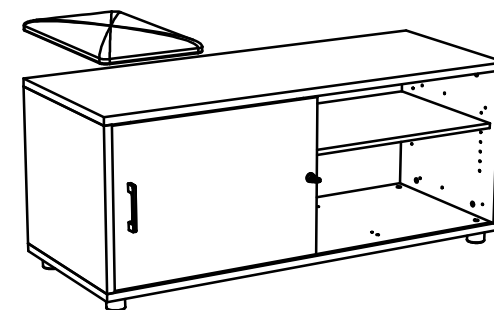
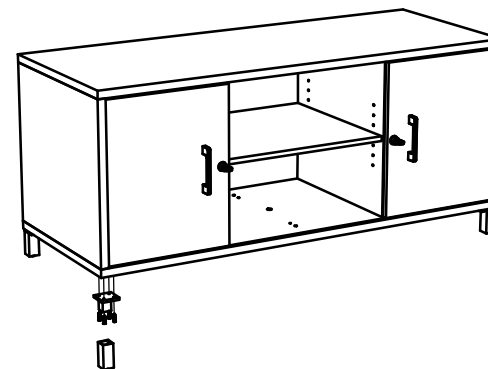
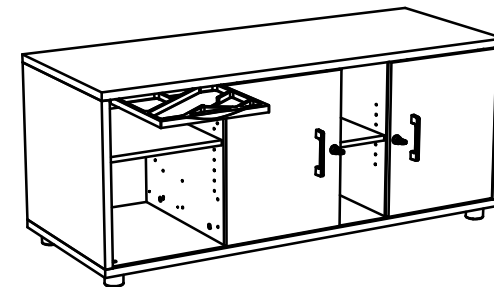
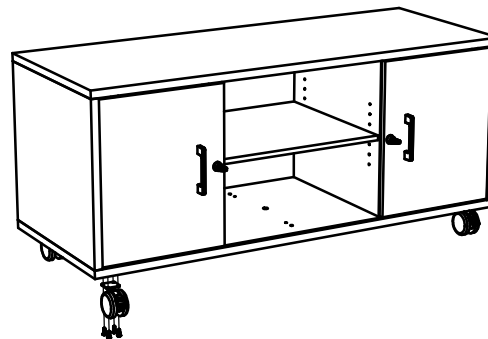

NOMENCLATURE

(Parts list)
(Stückliste)
(Onderdelenlijst)
(Nomenclatura)
(Lista de peças)

QUINCAILLERIE

(Hardware)
(Beschiège)
(Ijzerwaren)
(Ferramentas)
(Herrajes)
(Quinquilharia)

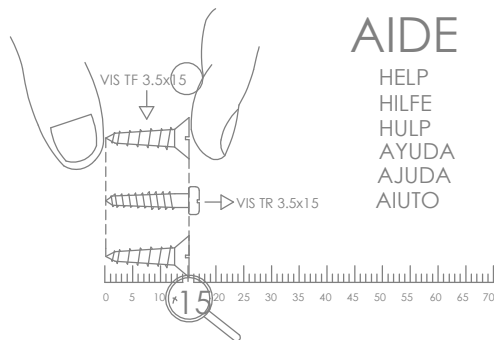

AIDE

HELP
HILFE
HULP
AYUDA
AJUDA
AIUTO

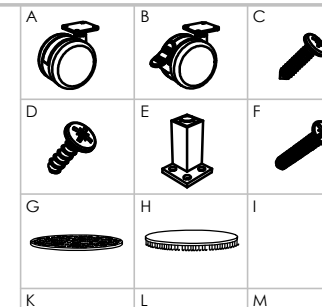
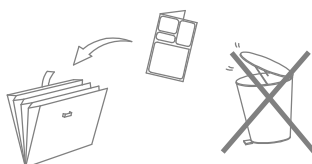

1

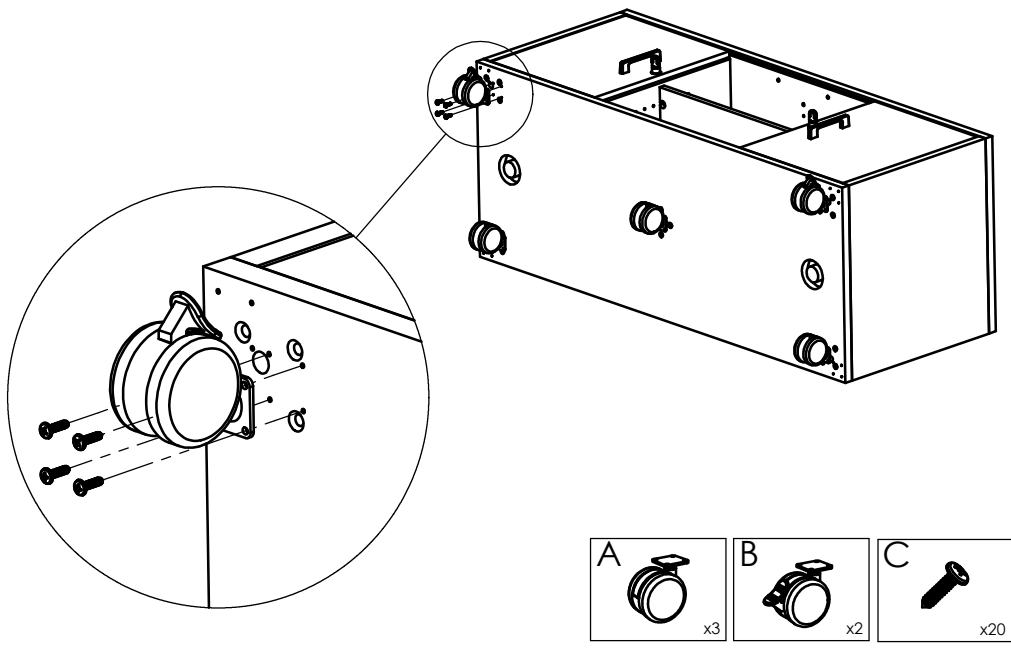

2

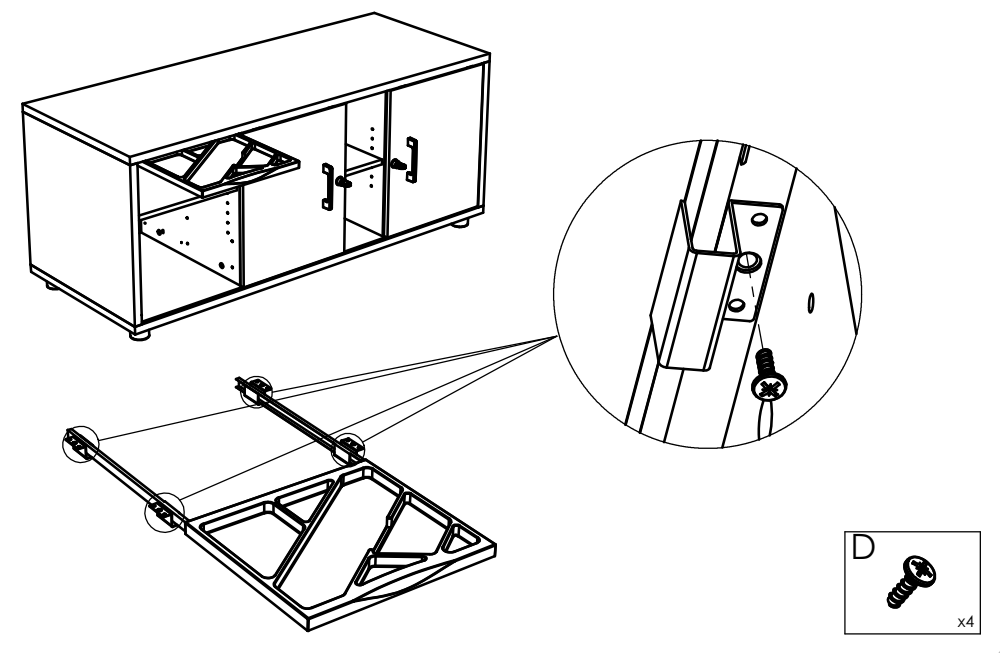

3

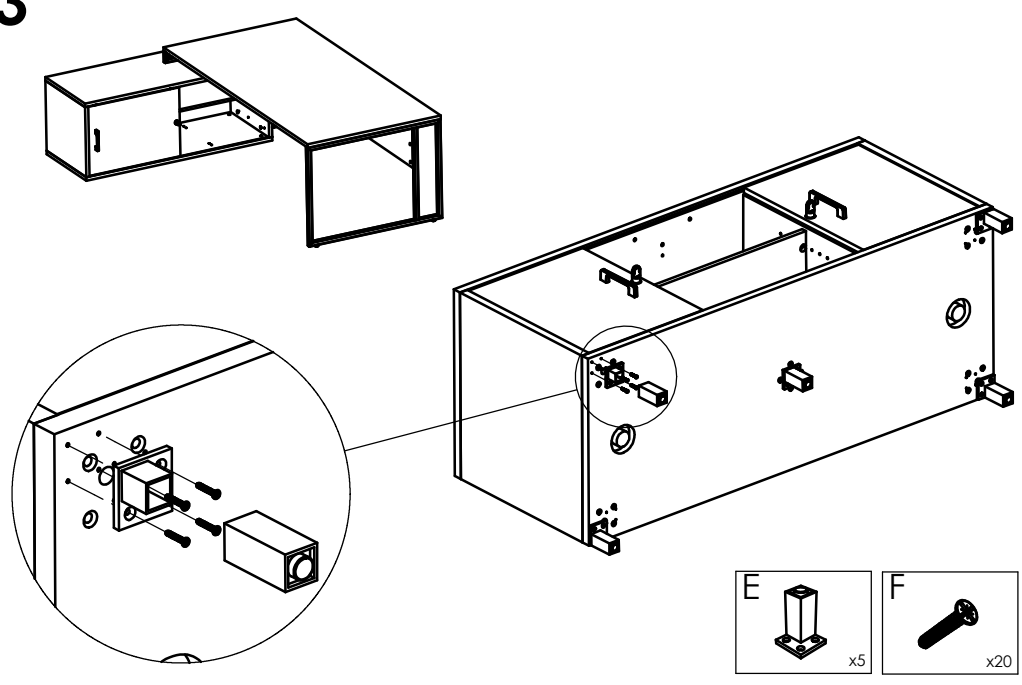

4

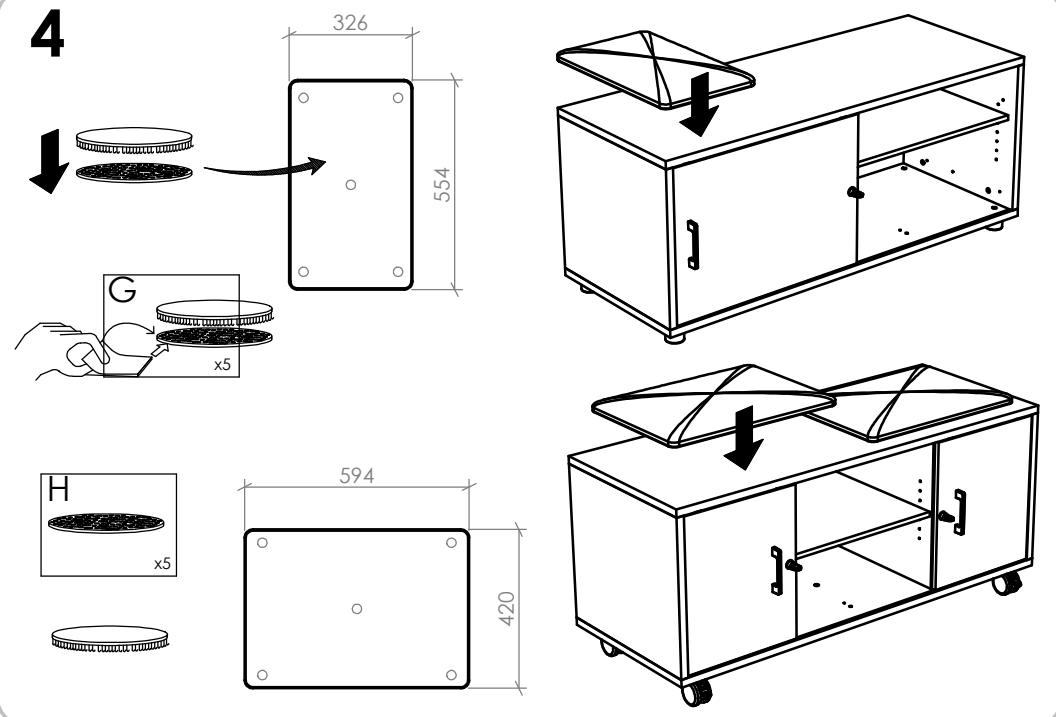

NOTICE DE MONTAGE
INSTRUCTIONS FOR ASSEMBLY
MONTAGEANLEITUNG
GEBRUIKSAANWIJZING
ISTRUZIONI DI MONTAGGIO
INSTRUCCIONES DE MONTAJE
INSTRUCCOES DE MONTAGEM

buronomic

FABRICANT FRANÇAIS

N°DV40410/02

CONCEPTION ET REALISATION BUREAU D'ETUDES BURONOMIC

GARANTIE (vices cachés)
_ Référence produit à nous communiquer impérativement en cas de litige :
Voir étiquette apposée au dos du produit

GARANTIE (defekt)
_ In the event of complaint, it is essential to mention the product reference :
See label affixed to the back of the product.

GARANTIE (fabrikationsfehler)
_ Im streifall sit uns die produktreferenz mitzuteilen :
Siehe etikett auf produckseite.

WAARBORG (de verborgen gebreken)
_ Vermeld in geval van klachten altijd het productnummer :
Zie label op de achterzijde van het product

GARANZIA (vizi oculti)
_ Specificare obbligatoriamente il riferimento prodotto in caso di contestazioni :
Si veda l'etichetta applicata dietro il prodotto

GARANTIA (defectos ocultos)
_ Referencia de producto citese obligatoriamente en caso de reclamacion :
Ver etiqueta en la parte posterior del producto.

GARANTIA (vices ocultos)
_ Em caso de reclamacao indiqu-nos imperativamente a referencia do produto :
Ver etiqueta fixada na parte posterior do produto

20 Mn

TOOLS: Screwdriver, Hammer, Allen key, Pencil.

CLEANING INSTRUCTIONS:

- NE PAS UTILISER DE PRODUITS CHIMIQUES
- NE PAS UTILISER DE PRODUITS ABRASIFS
- NE PAS UTILISER DE PRODUITS CORROSIFS

CLEANING PRODUCTS:

- ALCOOL A BRÛLER / METHYLATED SPIRITS / BRENNSPIRITUS / ETANOL / ALCOHOL DE QUEMAR / ALCOOL ETILICO
- CHIFFON DOUX / SOFT RAG / LAPPEN / ZACHTE DOEK / FANNO MORBIDO / FANNO SUIAVE / FANNO MACIO
- SAVON / SOAP / SEIFE / ZEEP / SABONE / JABON / SABAO
- CIRE / WAX / WACHS / WAS / CERA

AIDE

HELP
HILFE
HULP
AYUDA
AJUDA
AIUTO

VIS TF 3.5x15
VIS TR 3.5x15

0 5 10 15 20 25 30 35 40 45 50 55 60 65 70

DV40684/02

2
1

REP.	PIÉCE	QTÉ
1	PLATEAU	1
2	PIED 800 BOIS	2
A	VIS TBHC M6X16	4
B	CLÉ 6 PANS 4mm	1

DV40541/02

2
1

REP.	PIÉCE	QTÉ
1	PLATEAU	1
2	PIED ARCHE ASTRO	1
B	CLÉ 6 PANS 4mm	1
C	VIS TFHC 6X65	4

DV40684/02

2
1

REP.	PIÉCE	QTÉ
1	PLATEAU	1
2	PIED ASTROLITE	1
B	CLÉ 6 PANS 4mm	1
C	VIS TFHC 6X65	4
D	RONDELLE FRAISEE	4

