

NOTICE DE MONTAGE
INSTRUCTIONS FOR ASSEMBLY
MONTAGEANLEITUNG
GEBRUIKSAANWIJZING
ISTRUZIONI DI MONTAGGIO
INSTRUCCIONES DE MONTAJE
INSTRUÇÕES DE MONTAGEM

buronomic
FABRICANT FRANÇAIS

N° DV40830/01

CONCEPTION ET REALISATION BUREAU D'ETUDES BURONOMIC

GARANTIE (vices cachés)
_ Référence produit à nous communiquer impérativement en cas de litige :
Voir étiquette apposée au dos du produit

GARANTIE (defekt)
_ In the event of complaint, it is essential to mention the product reference :
See label affixed to the back of the product.

GARANTIE (fabrikationsfeil)
_ Im streifall sit uns die produktreferenz mitzuteilen :
Siehe etikett auf produktrückseite.

WAARBORG (de verborgen gebreken)
_ Vermeld in geval van klachten altijd het productnummer :
Zie label op de achterzijde van het product

GARANZIA (vizi occulti)
_ Specificare obbligatoriamente il riferimento prodotto in caso di contestazioni :
Si veda l'etichetta applicata dietro il prodotto

GARANTIA (defectos ocultos)
_ Referencia de producto citese obligatoriamente en caso de reclamacion :
Ver etiqueta en la parte posterior del producto.

GARANTIA (vices ocultos)
_ Em caso de reclamacao indiqu-nos imperativamente a referencia do produto :
Ver etiqueta fixada na parte posterior do produto

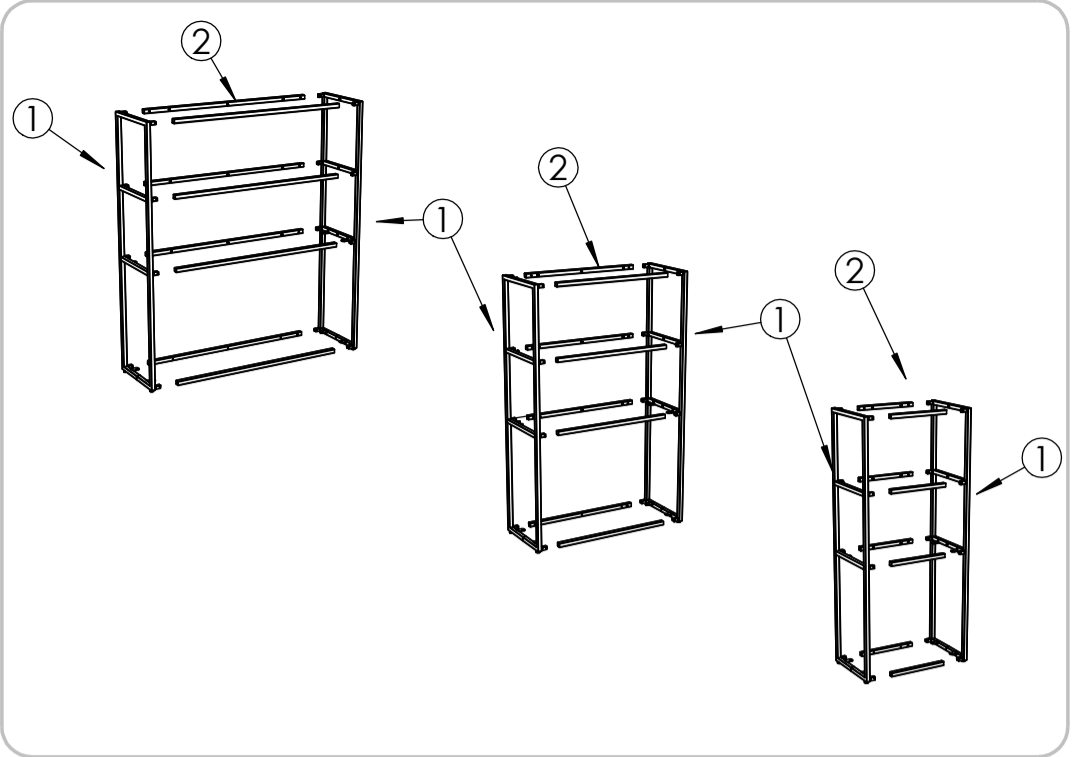
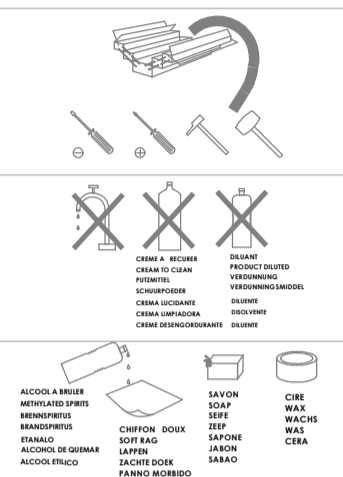
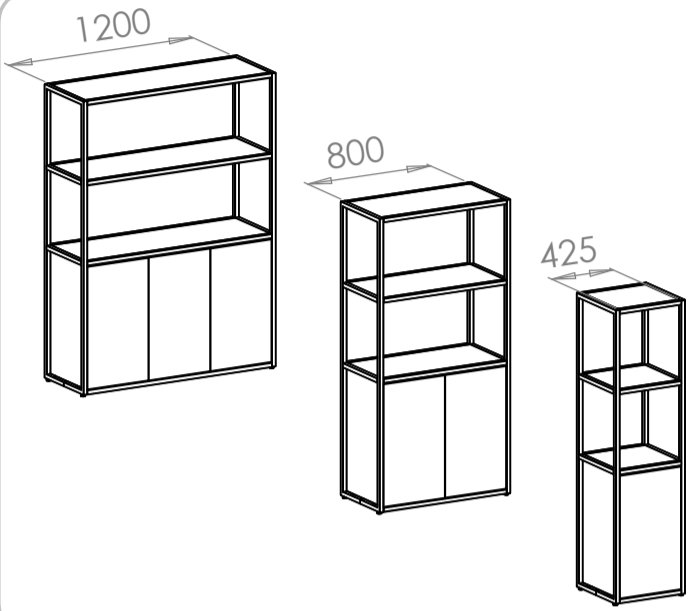

NOMENCLATURE (Parts list)
(Stückliste)
(Onderdelenlijst)
(Nomenclatura)
(Lista de peças)

Rep.	Pièce	Qté
1	Montant ext.	2
2	Traverse tube	8
3	TABLETTE	3
4	Rangement Biblio	1

QUINCAILLERIE (Hardware)
(Beschläge)
(Ijzerwaren)
(Ferramenta)
(Herrajes)
(Quinquilharia)

Rep.	Pièce	Qté	A	B	C	D	E	F	G	H	I	J	K	L	M	N	O	P	Q	R
A	Fixation Traverse	8																		
B	Fixation Equerre	4																		
C	Vis TF M5x16	16																		
D	Vis TF M5x10	24																		
E	Vis exp.	18/24																		
F	Vis Euro L 13mm	8																		
G	Clé 6 pans 3 mm	1																		

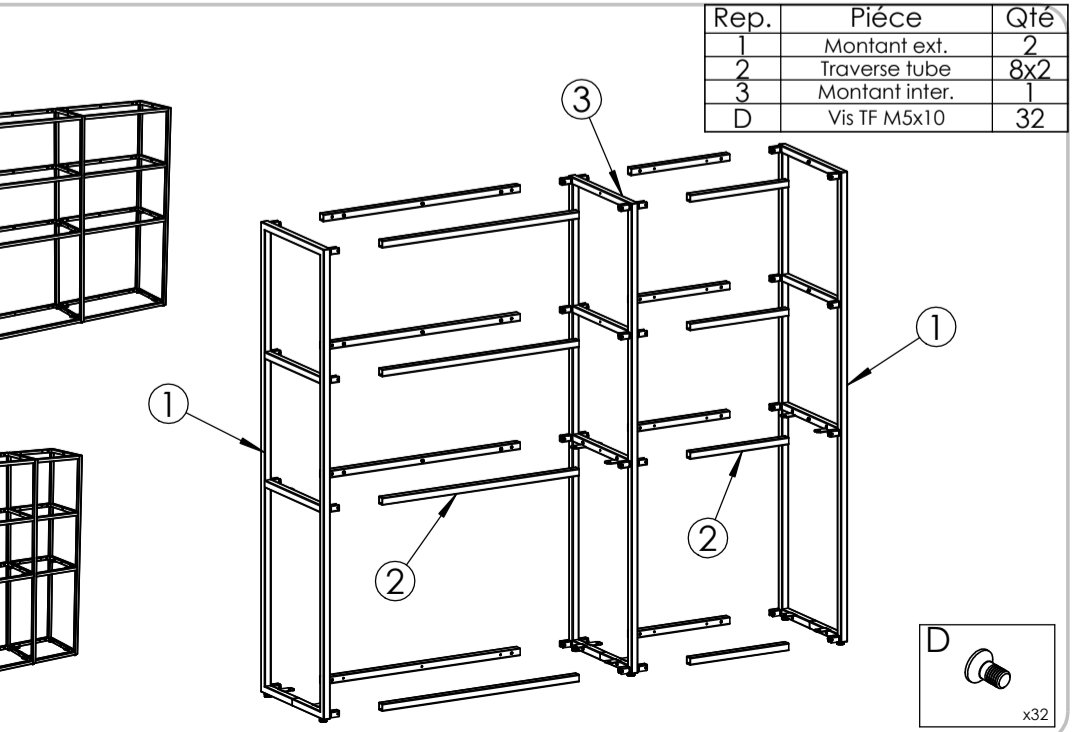
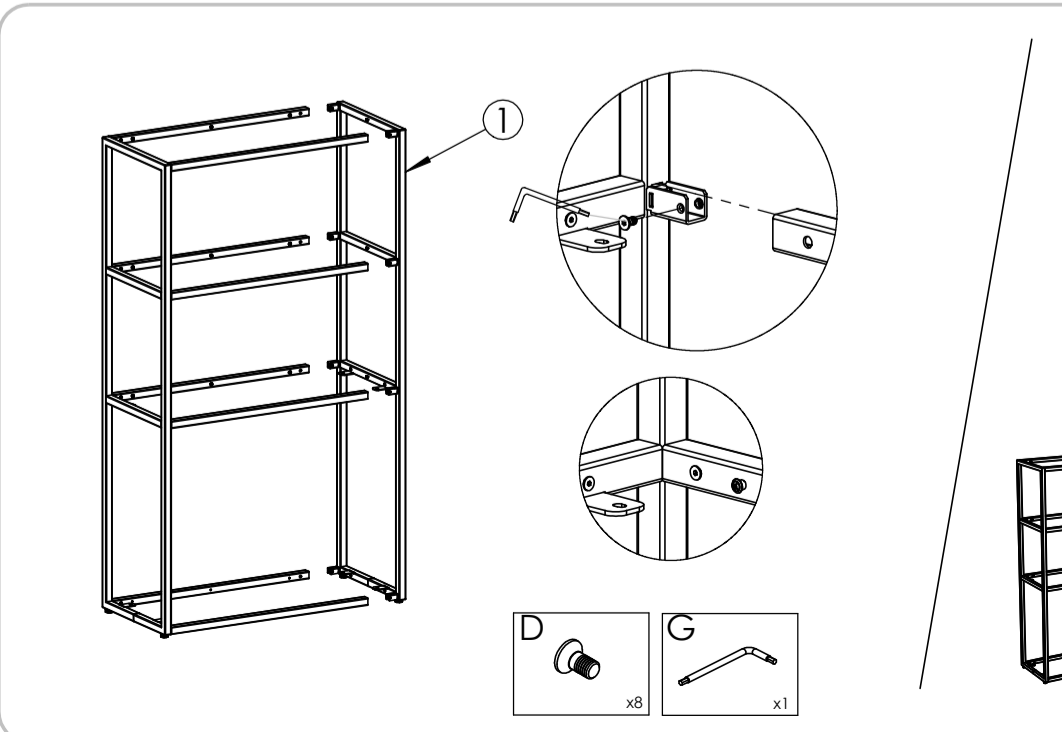
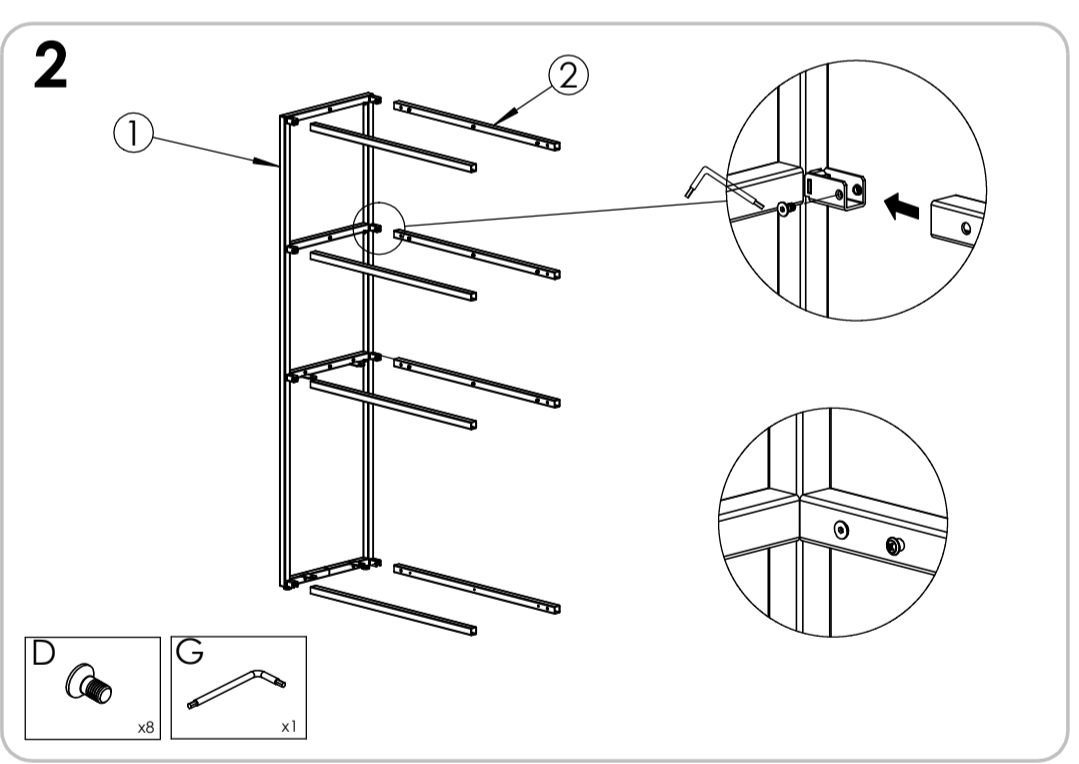
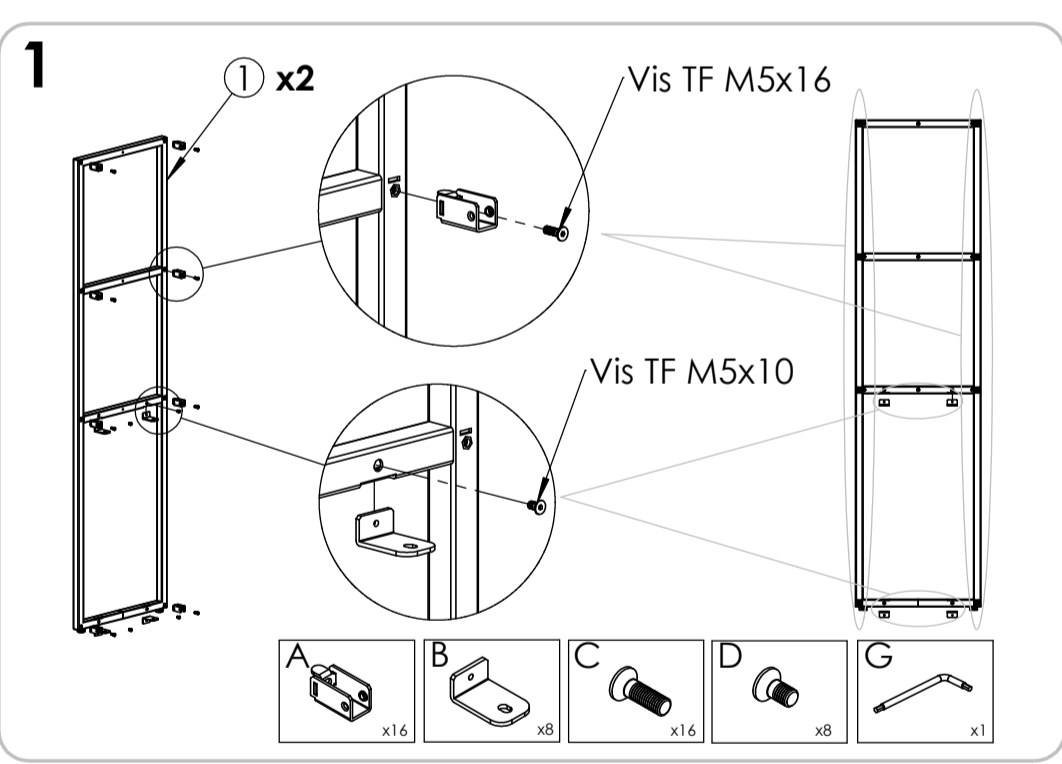
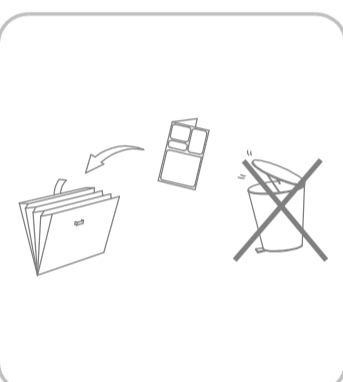
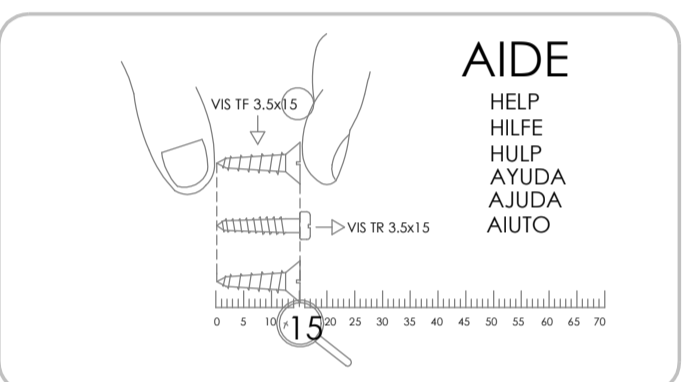

Rep.	Pièce	Qté
1	Montant ext.	2
2	Traverse tube	8x2
3	Montant inter.	1
D	Vis TF M5x10	32

3

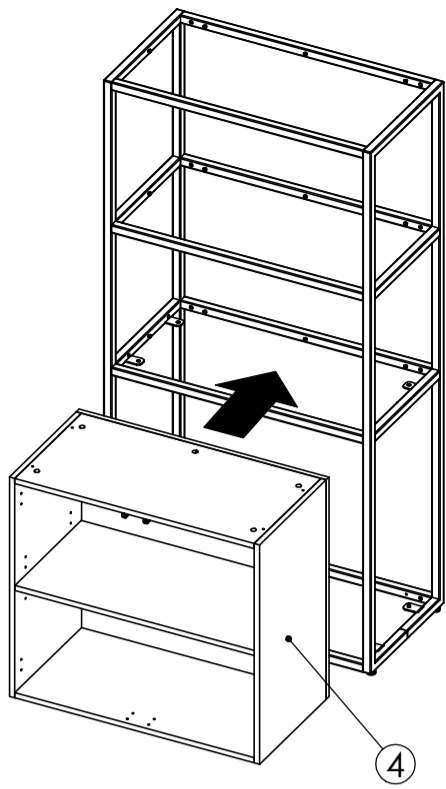

4

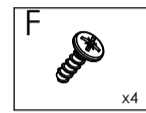
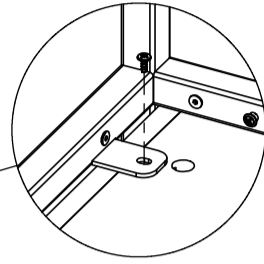
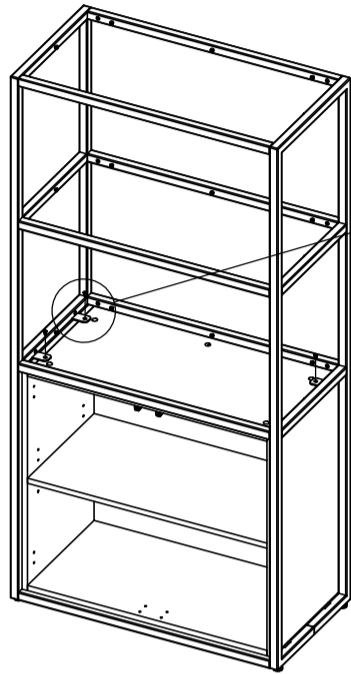

5

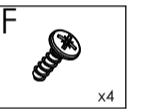
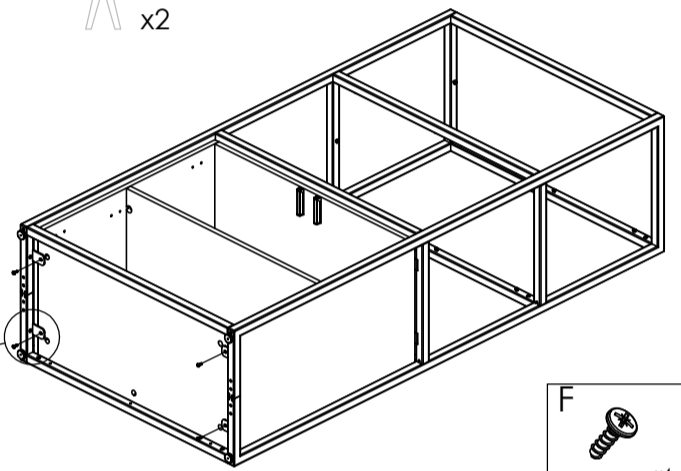
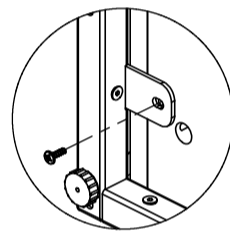

6

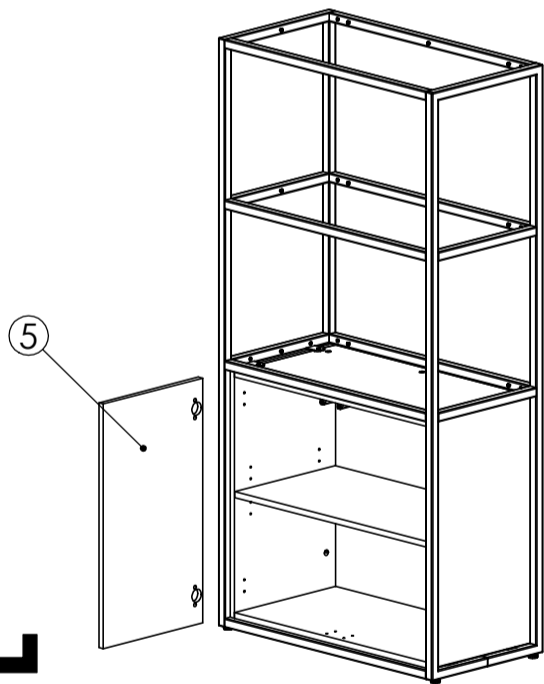

DV40554

7

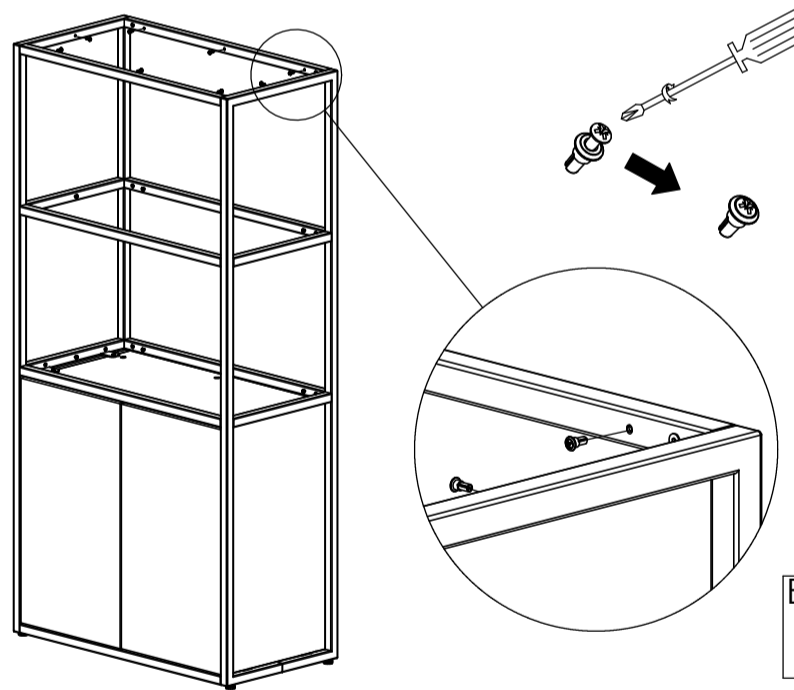

8

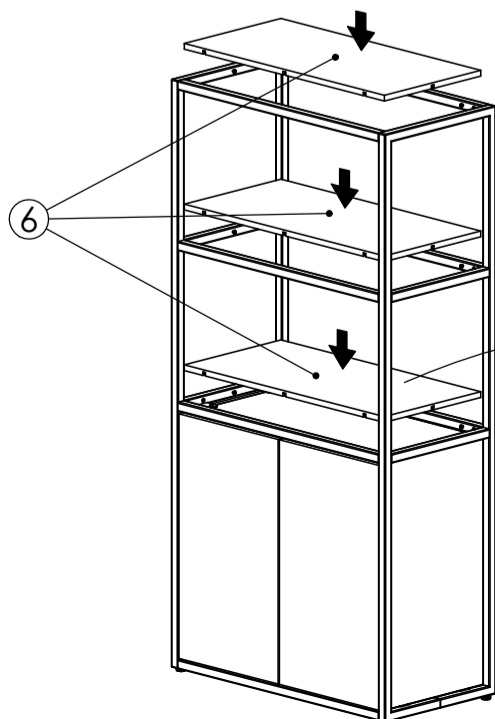

Option
Optioneel
Opzione
Opcional
Opção

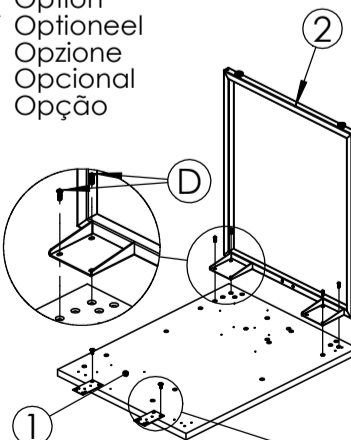

Rep.	Pièce	Qté
1	TOP	1
2	PIED de RETOUR	1
A	Platine 92x48	2
B	Vis TRL M6x15	2
C	Vis 4x15	6
D	VIS TCHC M6x16	4

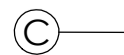
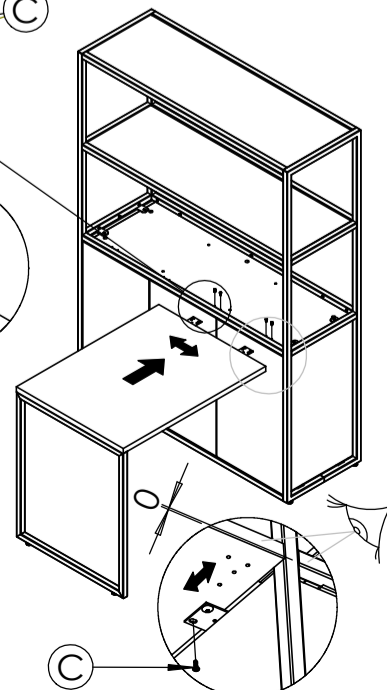
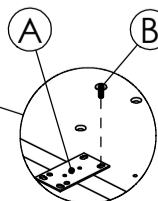
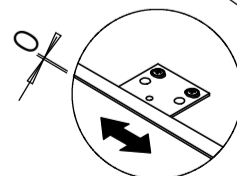
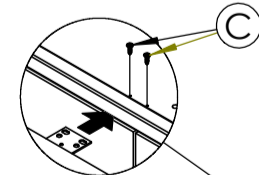

NOTICE DE MONTAGE
INSTRUCTIONS FOR ASSEMBLY
MONTAGEANLEITUNG
GEBRUIKSAANWIJZING
ISTRUZIONI DI MONTAGGIO
INSTRUCCIONES DE MONTAJE
INSTRUCCOES DE MONTAGEM

buronomic
FABRICANT FRANÇAIS

N° DV40829/02

CONCEPTION ET REALISATION BUREAU D'ETUDES BURONOMIC

GARANTIE (vices cachés)
_ Référence produit à nous communiquer impérativement en cas de litige :
Voir étiquette apposée au dos du produit

GARANTIE (defekt)
_ In the event of complaint, it is essential to mention the product reference :
See label affixed to the back of the product.

GARANTIE (fabrikationsfeil)
_ Im streitfall sit uns die produktreferenz mitzuteilen :
Siehe etikett auf produckdruckseite.

WAARBORG (de verborgen gebreken)
_ Vermeld in geval van klachten altijd het productnummer :
Zie label op de achterzijde van het product

GARANZIA (vizi occulti)
_ Specificare obbligatoriamente il riferimento prodotto in caso di contestazioni :
Si veda l'etichetta applicata dietro il prodotto

GARANTIA (defectos ocultos)
_ Referencia de producto citese obligatoriamente en caso de reclamacion :
Ver etiqueta en la parte posterior del producto.

GARANTIA (vices ocultas)
_ Em caso de reclamacao indiq-nos imperativamente a referéncia do produto :
Ver etiqueta fixada na parte posterior do produto

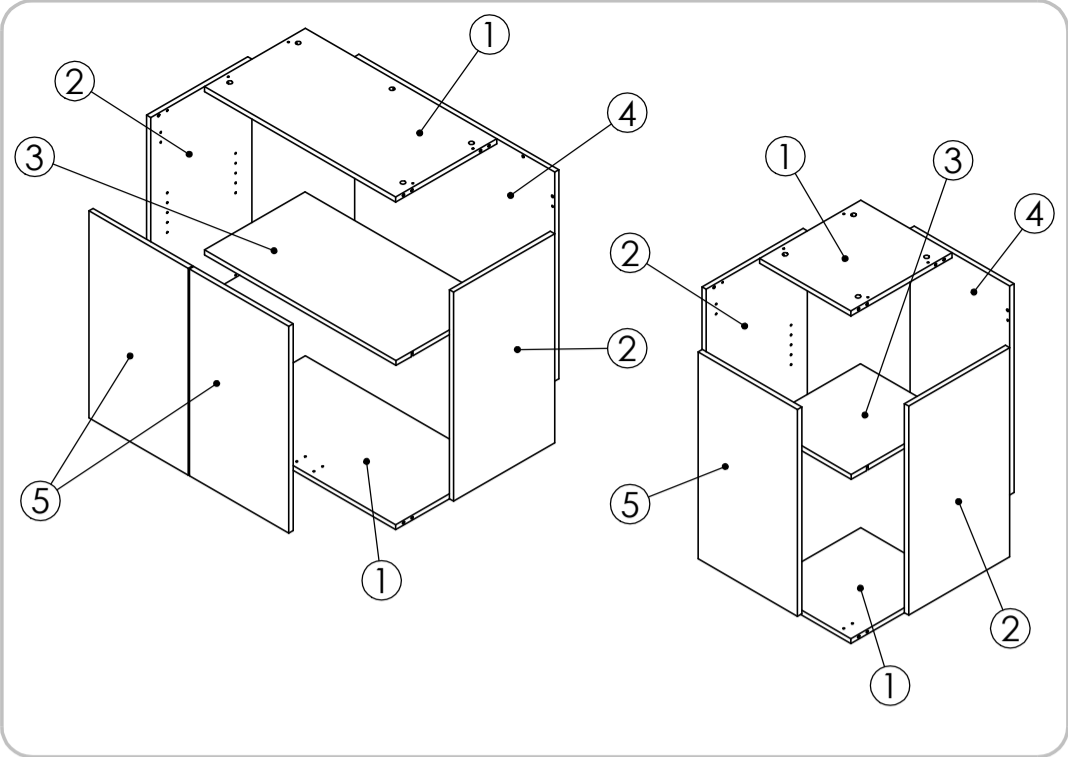
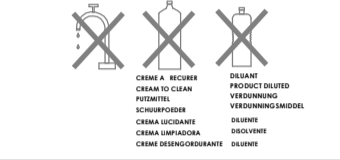
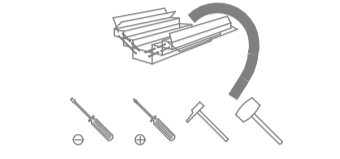
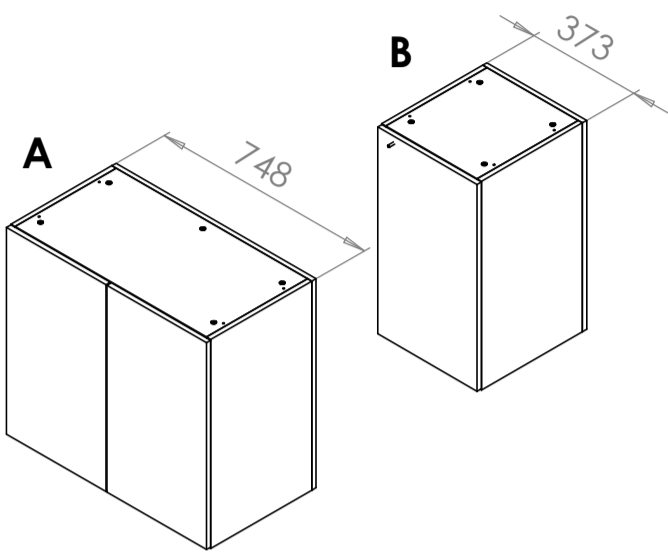

NOMENCLATURE

(Parts list)
(Stückliste)
(Onderdelenlijst)
(Nomenclatura)
(Lista de peças)

Rep.	Pièce	Qté	Qté
1	Fond / Dessus	2	2
2	Côté	2	2
3	PAR	1	1
4	Tablette	1	1
5	Porte	2	1

QUINCAILLERIE

(Hardware)
(Beschläge)
(Izzerwaren)
(Ferramenta)
(Herrajes)
(Quinquilharia)

Rep.	Pièce	Qté	Qté	A	B	C
A	Excentrique court	14	12			
B	Goujon bois	14	12			
C	Cale de charnière	4	2			
D	Charnière droite	2	2			
E	Tip On	2	1			
F	Vis Euro 6.3x13x7.7	4	-			
G	Vis exp.	4	4			
H	Cache excent.	1	1			

AIDE

HELP
HILFE
HULP
AYUDA
AJUDA
AIUTO

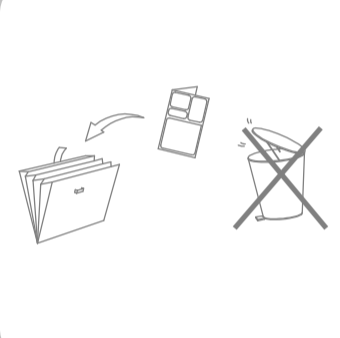
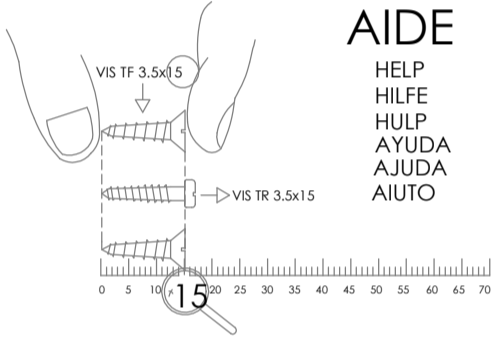

1

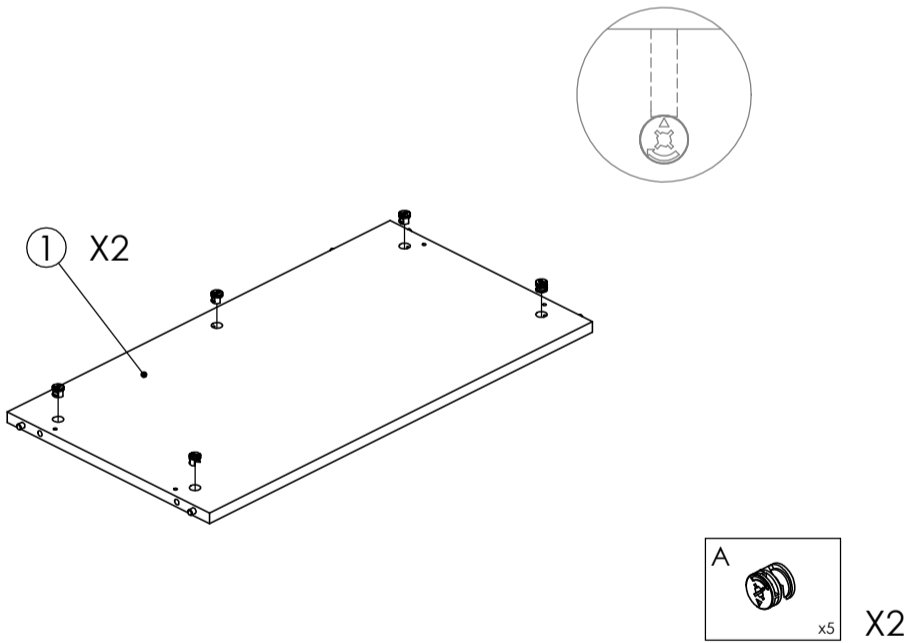

2

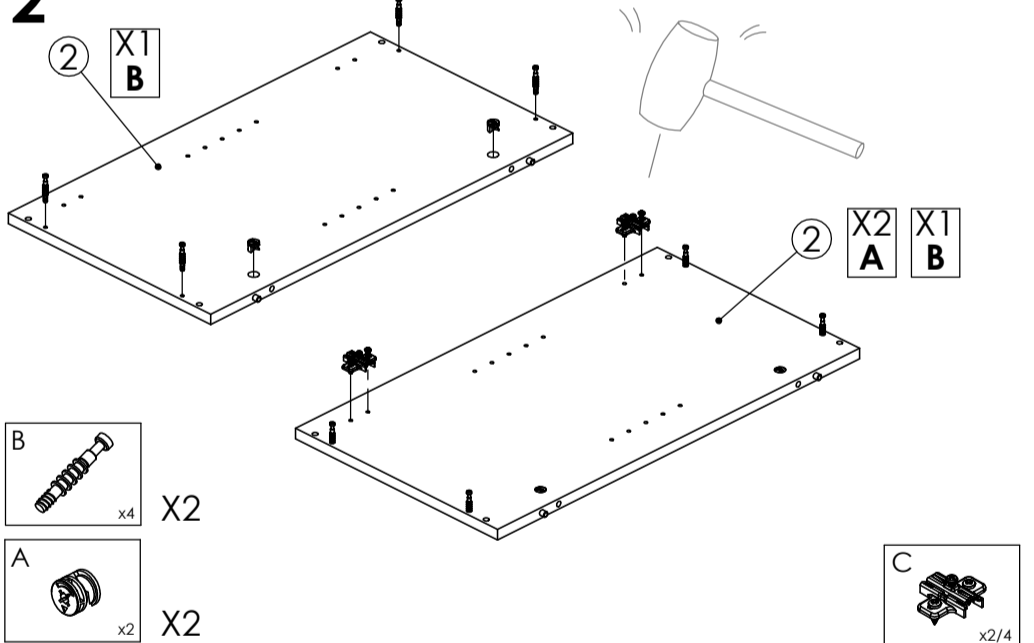

3

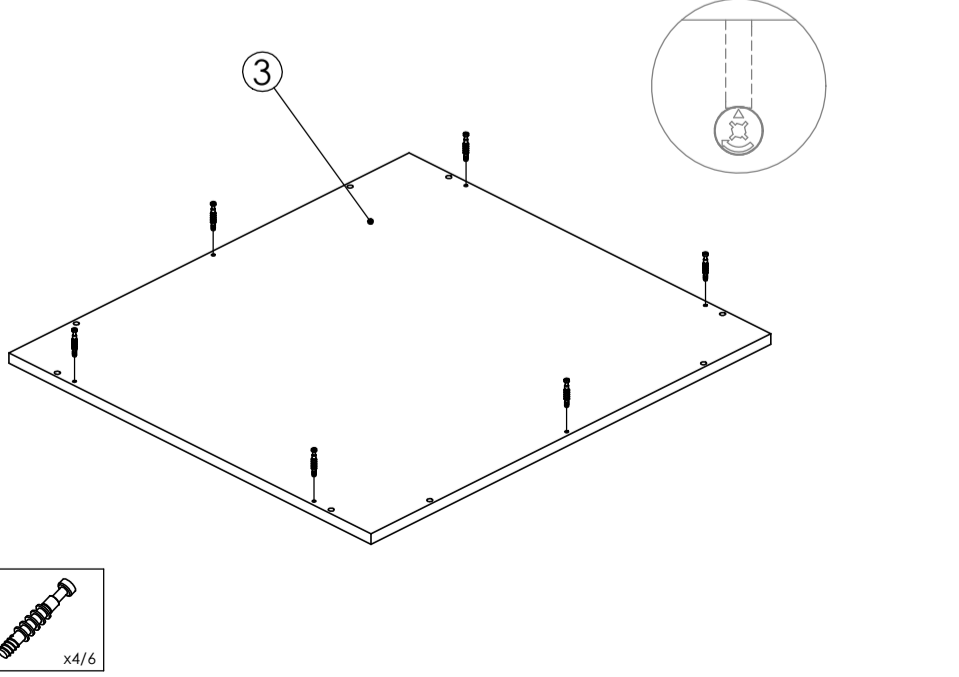

4

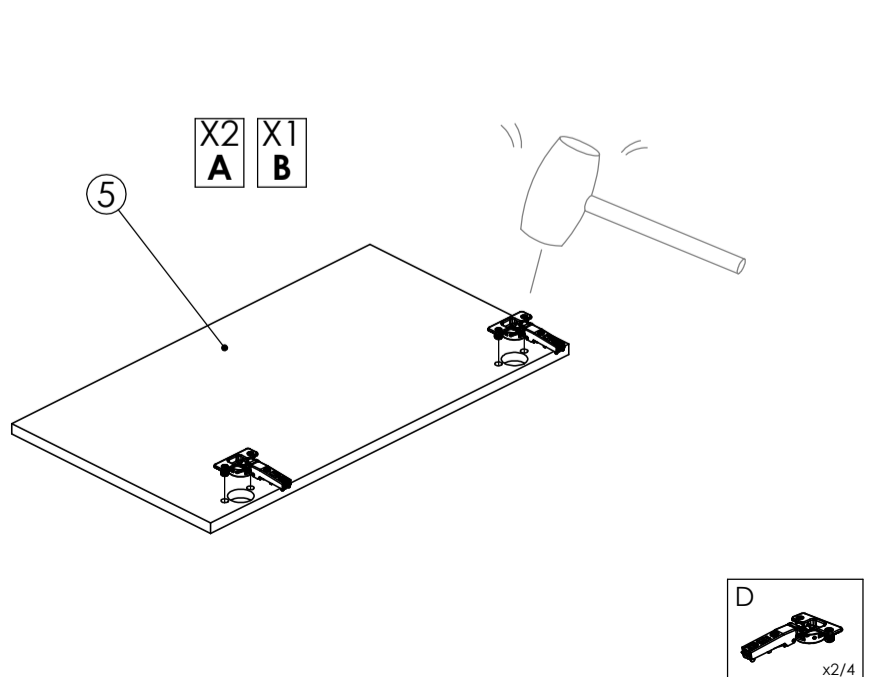

NOTICE DE MONTAGE
INSTRUCTIONS FOR ASSEMBLY
MONTAGEANLEITUNG
GEBRUIKSAANWIJZING
ISTRUZIONI DI MONTAGGIO
INSTRUCCIONES DE MONTAJE
INSTRUÇÕES DE MONTAGEM

buronomic
FABRICANT FRANÇAIS

N° DV40849/03

CONCEPTION ET REALISATION BUREAU D'ETUDES BURONOMIC

GARANTIE (vices cachés)
_ Référence produit à nous communiquer impérativement en cas de litige :
Voir étiquette apposée au dos du produit

GARANTIE (defekt)
_ In the event of complaint, it is essential to mention the product reference :
See label affixed to the back of the product.

GARANTIE (fabrikationsfeil)
_ Im streifall sit uns die produktreferenz mitzuteilen :
Siehe etikett auf produktrückseite.

WAARBORG (de verborgen gebreken)
_ Vermeld in geval van klachten altijd het productnummer :
Zie label op de achterzijde van het product

GARANZIA (vizi occulti)
_ Specificare obbligatoriamente il riferimento prodotto in caso di contestazioni :
Si veda l'etichetta applicata dietro il prodotto

GARANTIA (defectos ocultos)
_ Referencia de producto citese obligatoriamente en caso de reclamacion :
Ver etiqueta en la parte posterior del producto.

GARANTIA (vices ocultas)
_ Em caso de reclamacao indiqu-nos imperativamente a referencia do produto :
Ver etiqueta fixada na parte posterior do produto

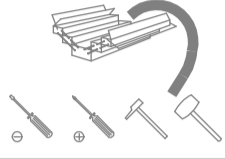
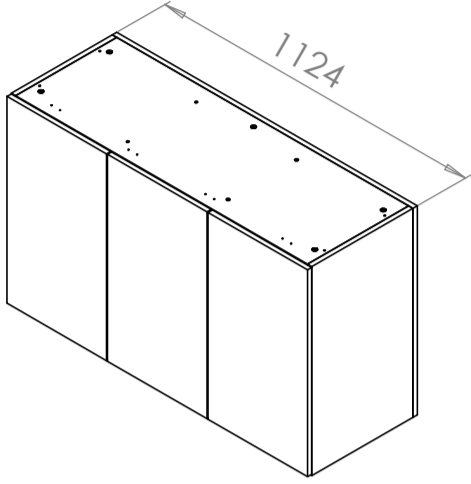
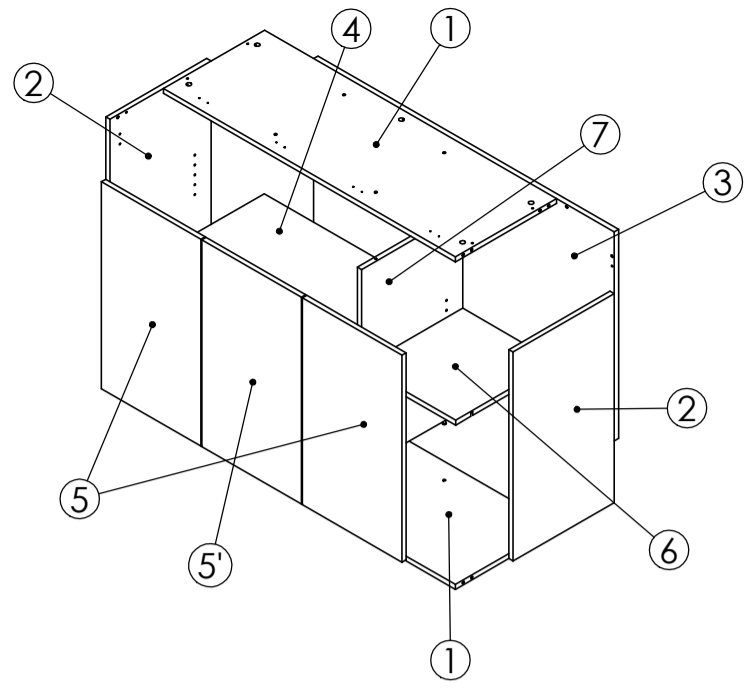

NOMENCLATURE

(Parts list)
(Stückliste)
(Onderdelenlijst)
(Nomenclatura)
(Lista de peças)

Rep.	Pièce	Qté
1	Fond / Dessus	2
2	Côté	2
3	PAR	1
4	Tablette longue	1
5	Porte	3
6	Tablette courte	1
7	Séparation	1

QUINCAILLERIE

(Hardware)
(Beschläge)
(Ijzerwaren)
(Ferramentas)
(Herrajes)
(Quinquilharia)

Rep.	Pièce	Qté
A	Excentrique court	14
B	Goujon bois	14
C	Cale de charnière	6
D	Charnière droite	2
F	Vis Euro 6.3x13x7.7	6
G	Vis exp.	8
H	Cache excent.	4
I	Vis 7x50	4
J	Clé 6 pans 4mm	1
K	Charnière 1/2 coudé	2

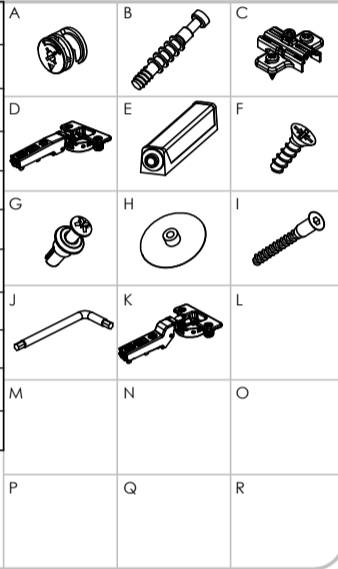

AIDE

HELP
HILFE
HULP
AYUDA
AJUDA
AIUTO

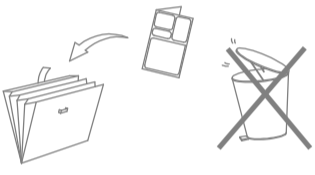
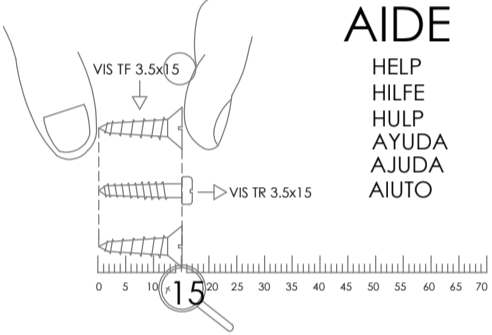

1

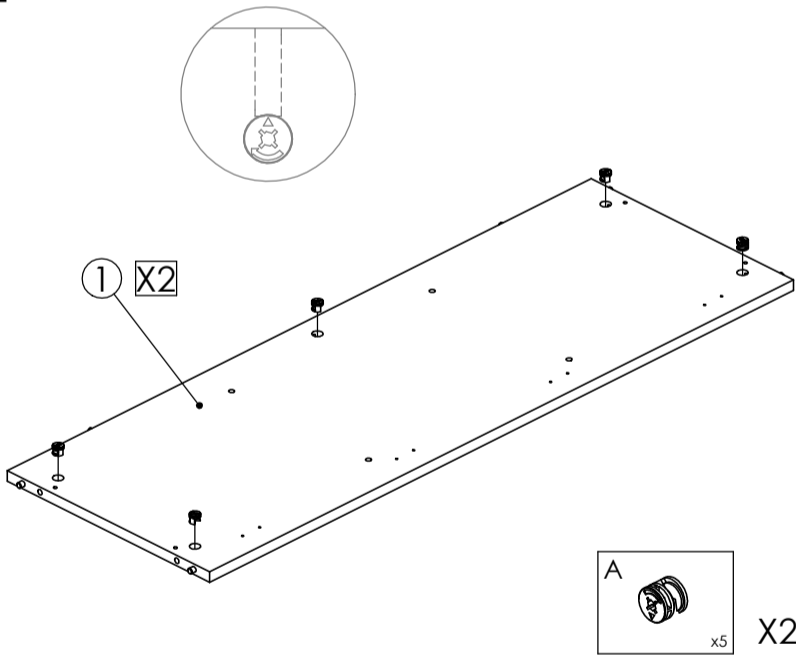

2

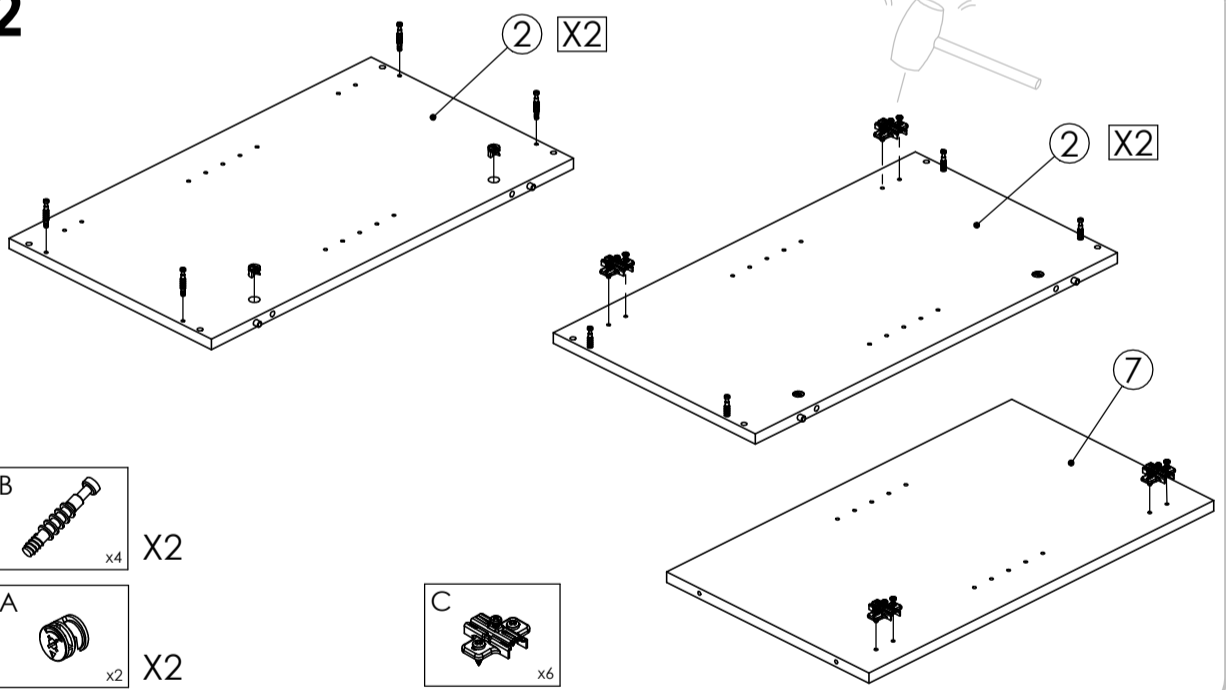

3

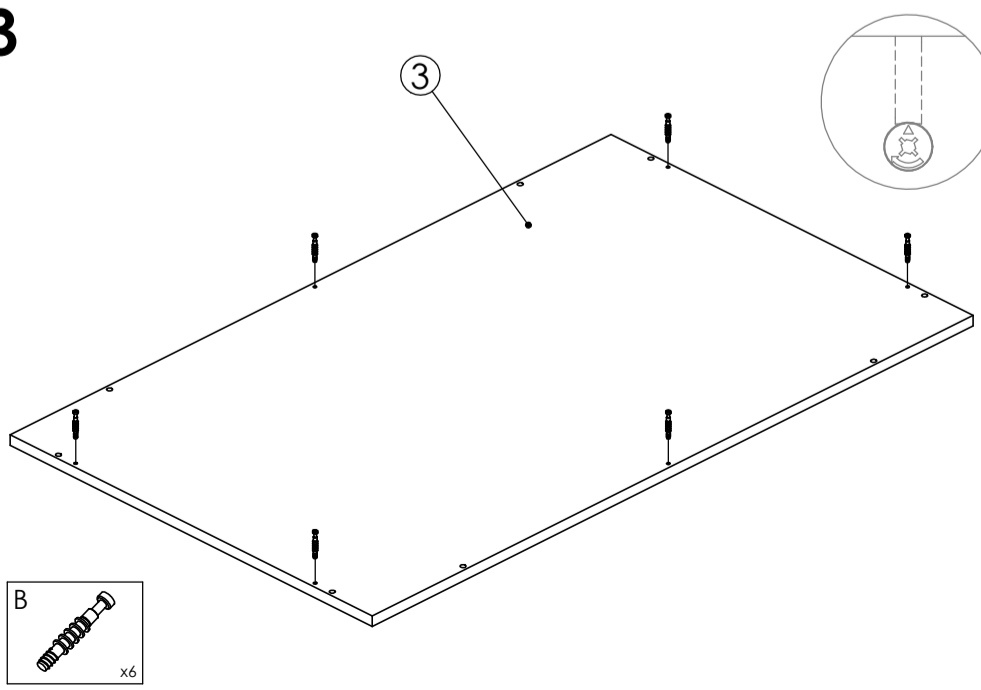

4

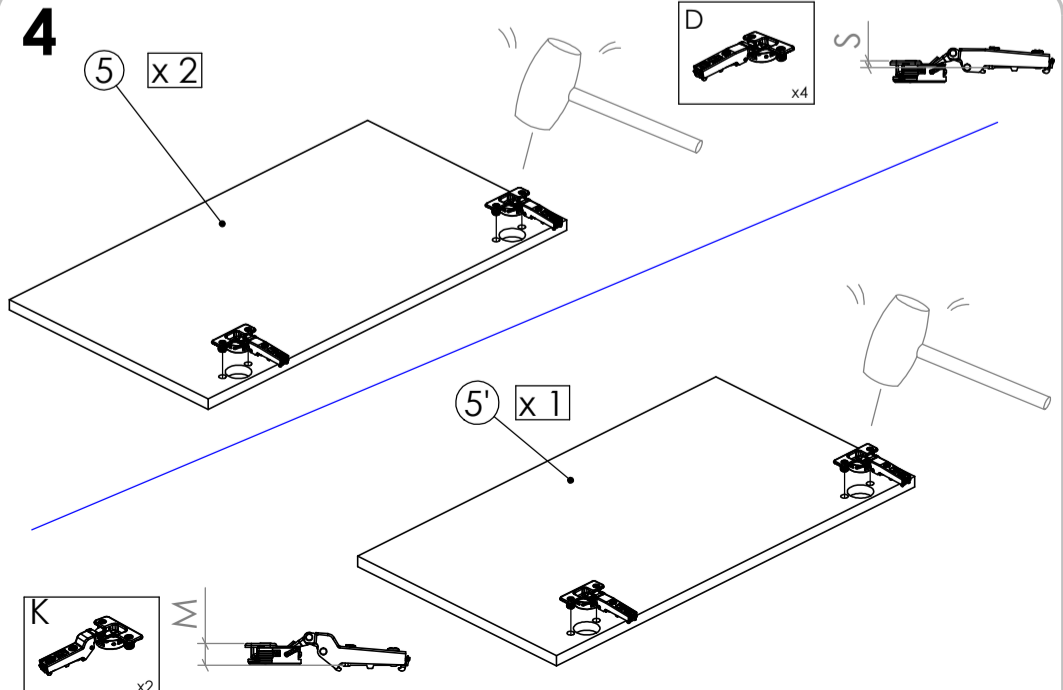

5

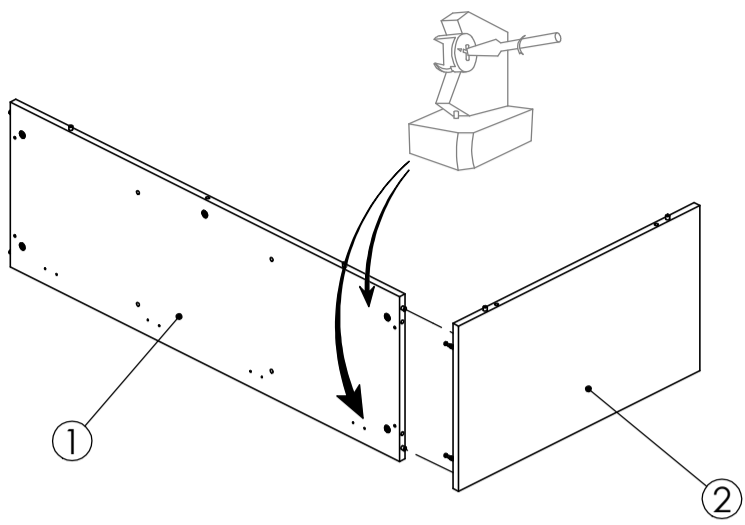

6

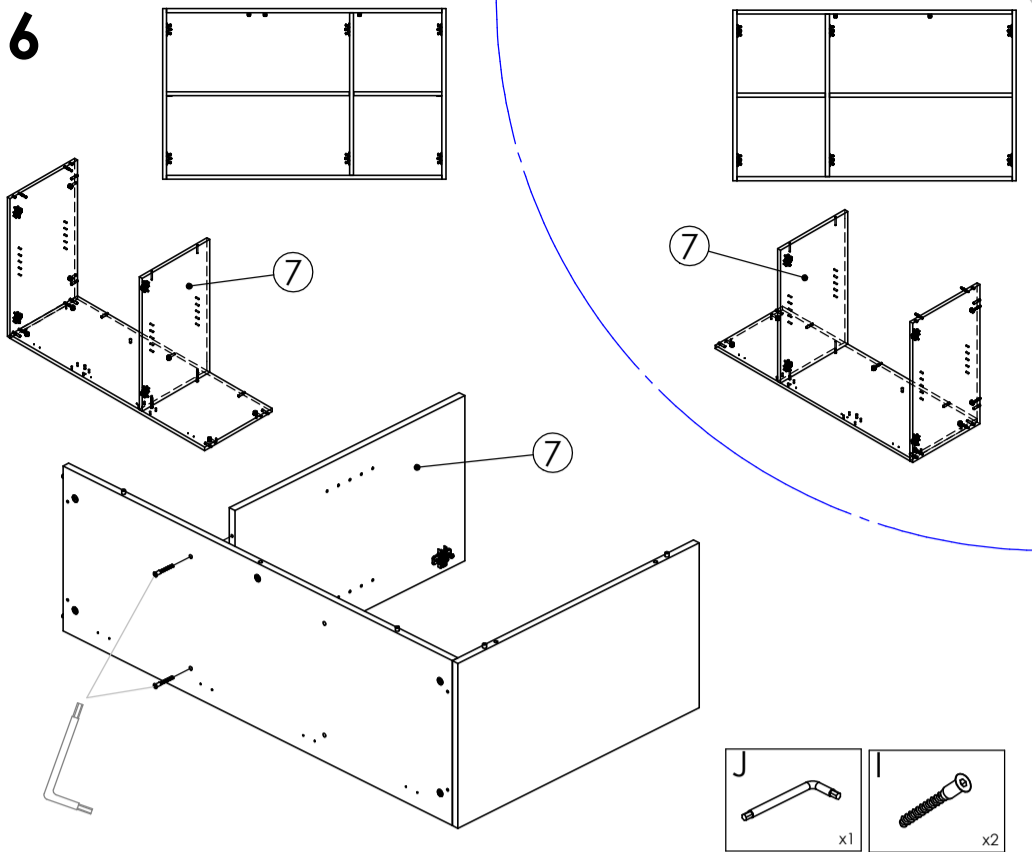

7

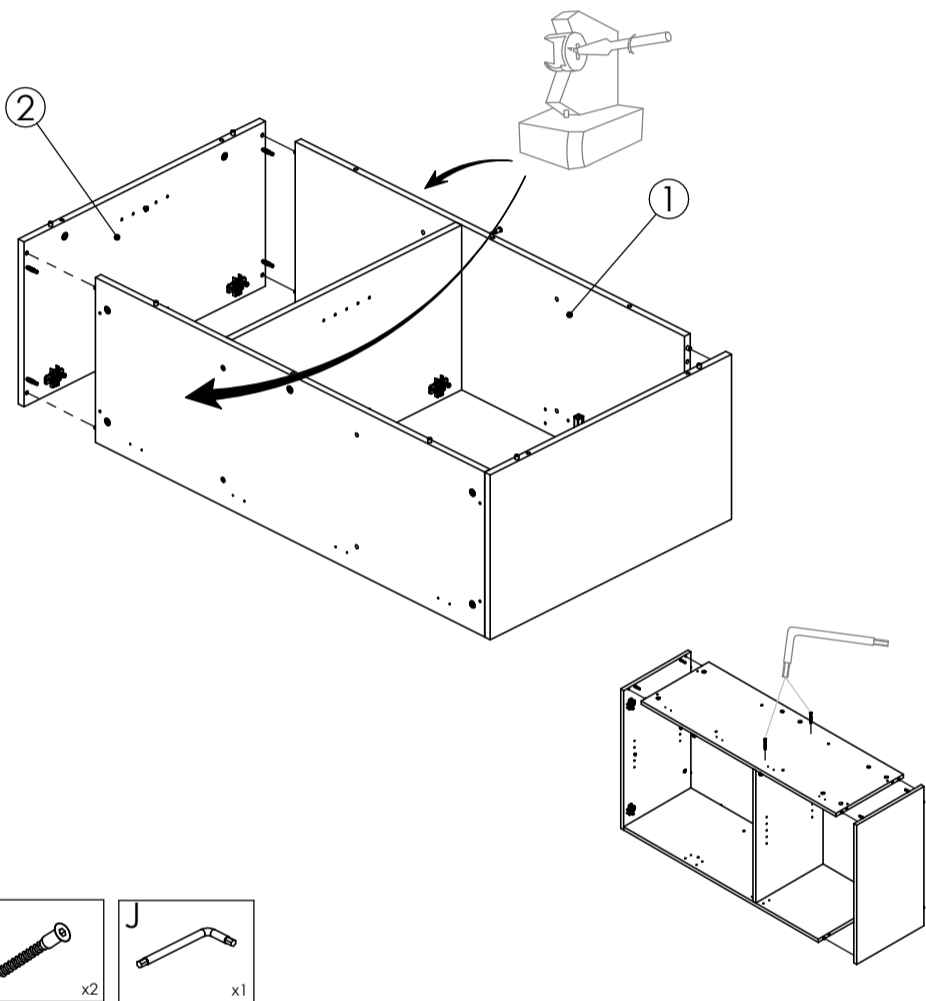

8

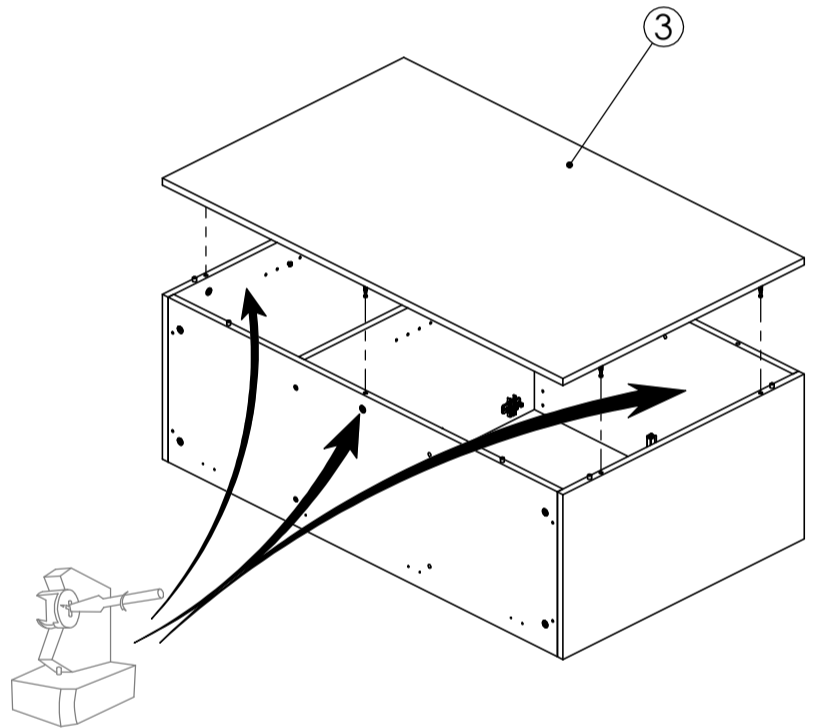

9

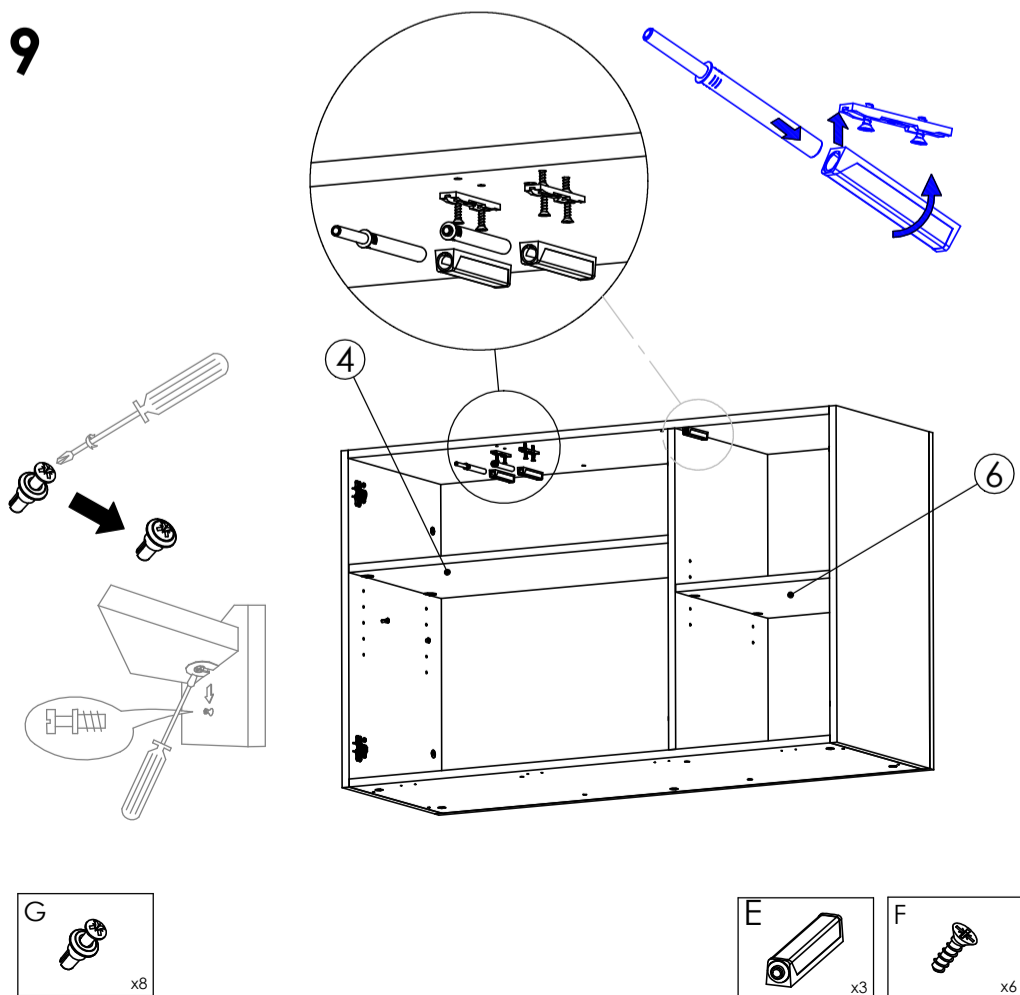

10

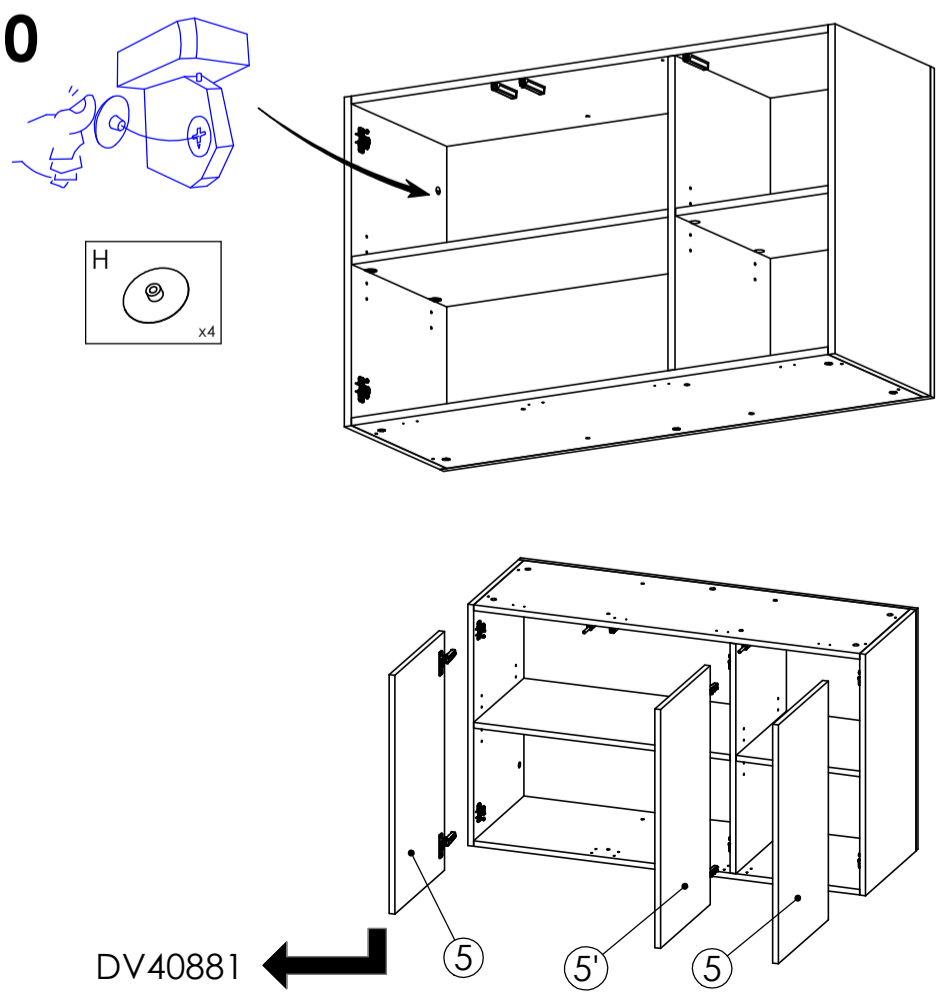

DV40881

5

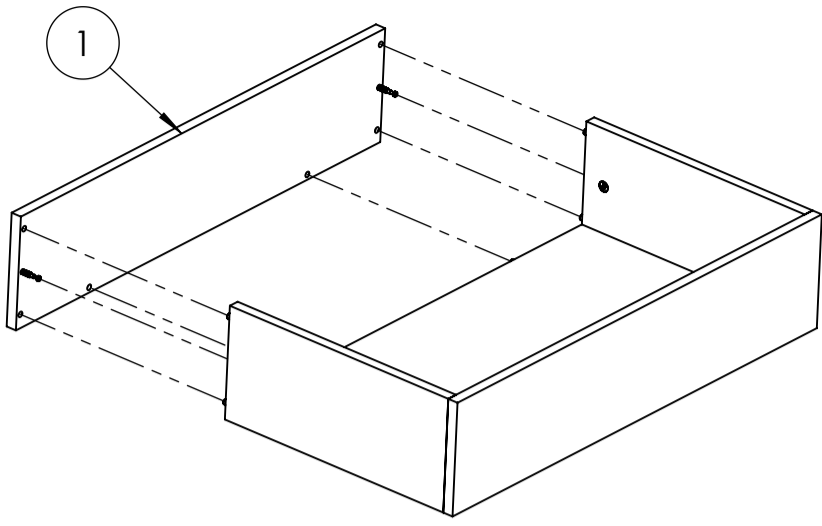

6

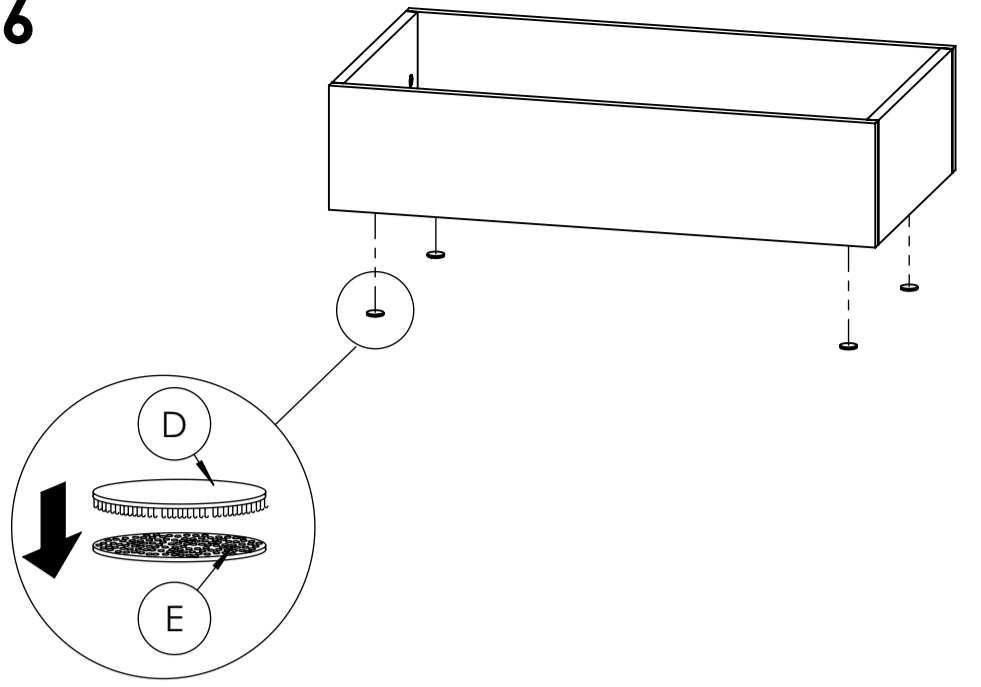

7

