

NOTICE DE MONTAGE
INSTRUCTIONS FOR ASSEMBLY
MONTAGEANLEITUNG
GEBRUIKSAANWIJZING
ISTRUZIONI DI MONTAGGIO
INSTRUCCIONES DE MONTAJE
INSTRUÇÕES DE MONTAGEM

buronomic
FABRICANT FRANÇAIS
N° DV40812

CONCEPTION ET REALISATION BUREAU D'ETUDES BURONOMIC

GARANTIE (vices cachés)
_ Référence produit à nous communiquer impérativement en cas de litige :
Voir étiquette apposée au dos du produit

GARANTIE (defekt)
_ In the event of complaint, it is essential to mention the product reference :
See label affixed to the back of the product.

GARANTIE (fabrikationsfelner)
_ Im streifall sit uns die produktreferenz mitzuteilen :
Siehe etikett auf produktdruckseite.

WAARBORG (de verborgen gebreken)
_ Vermeld in geval van klachten altijd het productnummer :
Zie label op de achterzijde van het product

GARANZIA (vizi occulti)
_ Specificare obbligatoriamente il riferimento prodotto in caso di contestazioni :
Si veda l'etichetta applicata dietro il prodotto

GARANTIA (defectos ocultos)
_ Referencia de producto citese obligatoriamente en caso de reclamacion :
Ver etiqueta en la parte posterior del producto.

GARANTIA (vices ocultos)
_ Em caso de reclamacao indiqu-nos imperativamente a referencia do produto :
Ver etiqueta fixada na parte posterior do produto

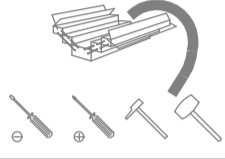
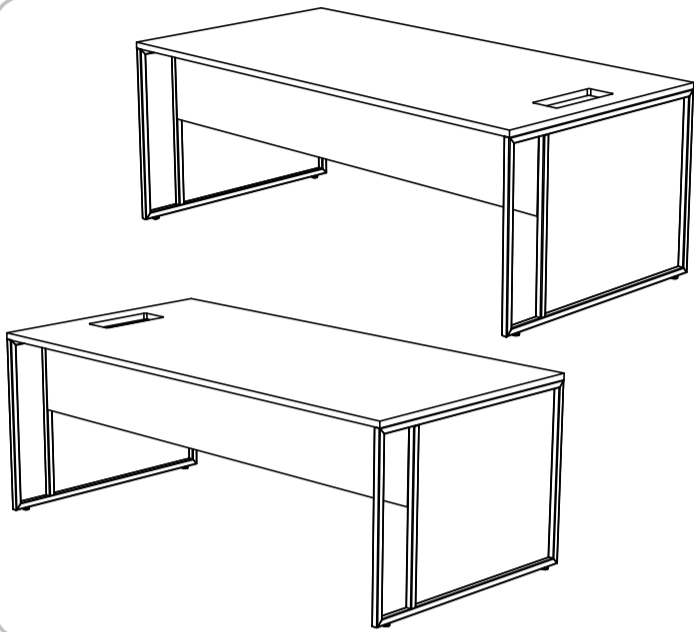
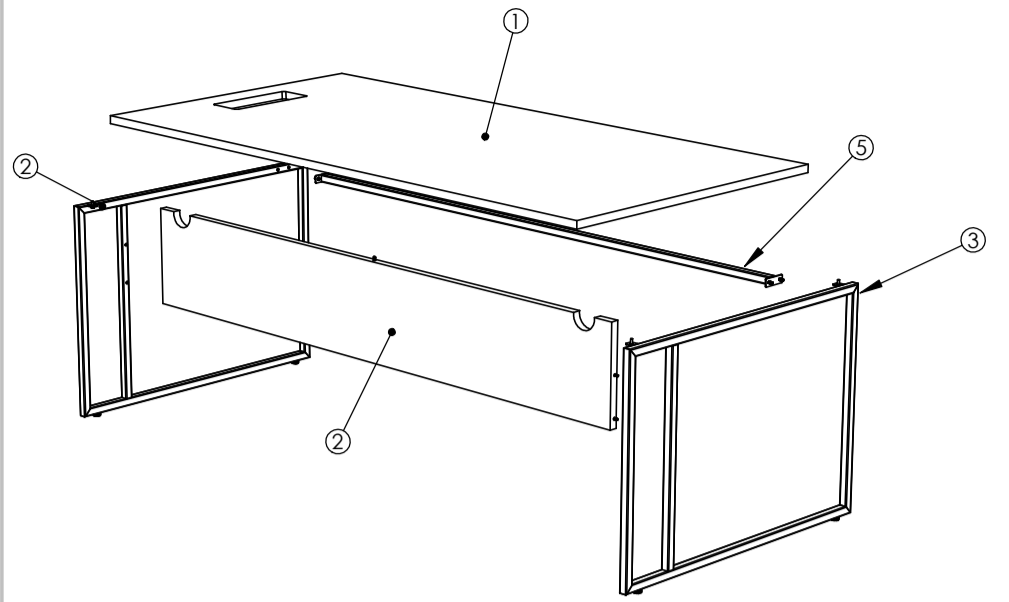

NOMENCLATURE

(Parts list)
(Stückliste)
(Onderdelenlijst)
(Nomenclatura)
(Lista de peças)

Rep.	Pièce	Qté
1	PLAN DE TRAVAIL TOP ACCESS	1
2	VDF	1
3	PIED 1000	1
4	PIED 1000	1
5	TRAVERSE	1

QUINCAILLERIE

(Hardware)
(Beschläge)
(Ijzerwaren)
(Ferramenta)
(Herrajes)
(Quinquilharia)

Rep.	Pièce	Qté	A	B	C
A	Excentrique Ø15	5			
B	Goujon métal	5			
C	VERIN Ø25 M8X17	4			
D	VIS TCHC M6x16	4			
E	VIS TBHc M6x16	8			
F	Clé 6 pans 4mm	1			
G	Clé 6 pans 5mm	1			
H	Cache excent.	5			
i*	GUIDE CABLE	1			
			J	K	L
			M	N	O
			P	Q	R

AIDE

HELP
HILFE
HULP
AYUDA
AJUDA
AIUTO

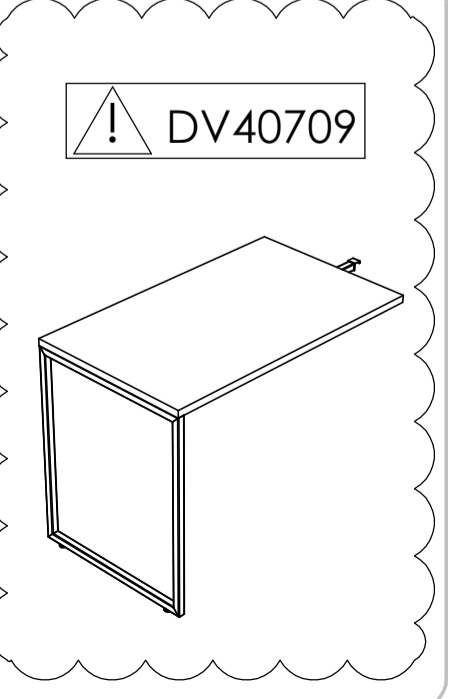
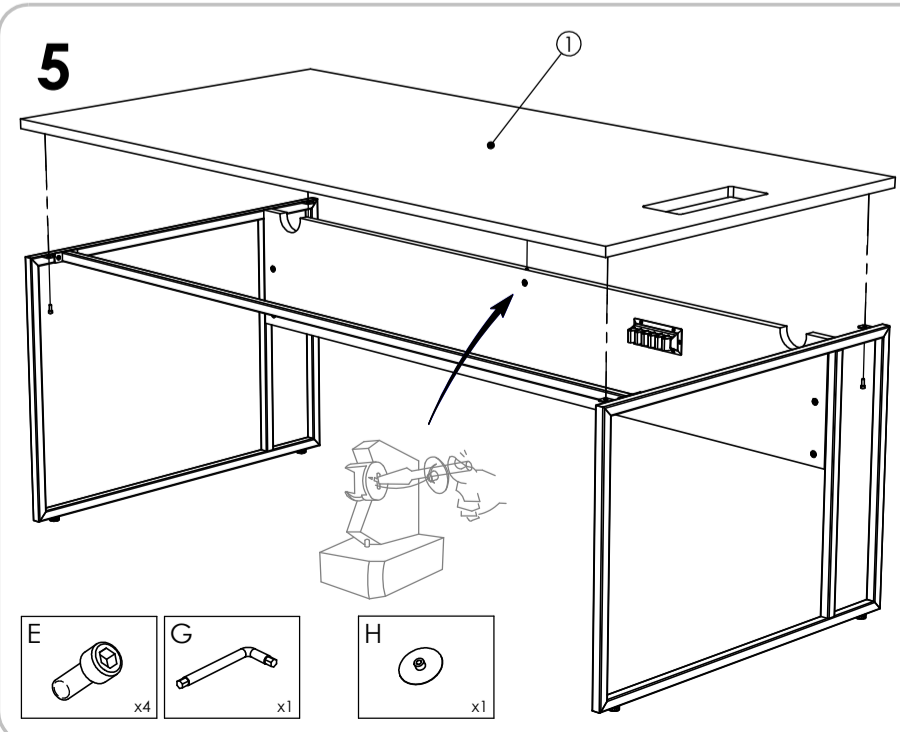
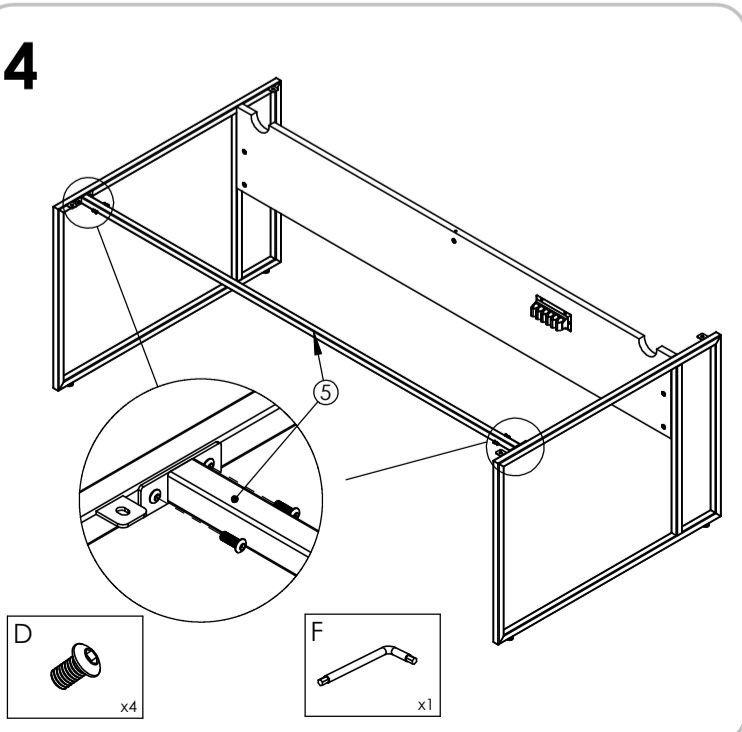
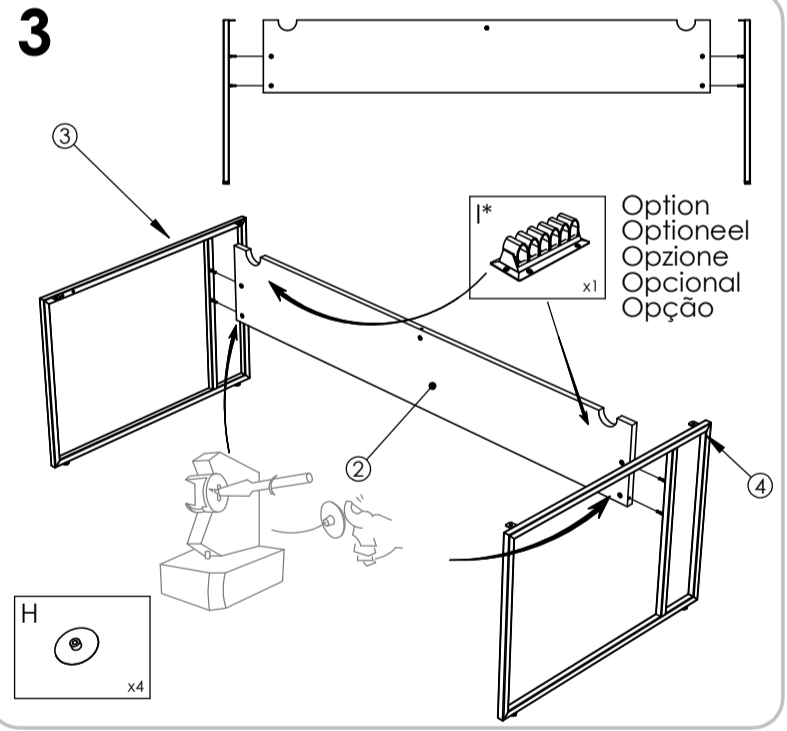
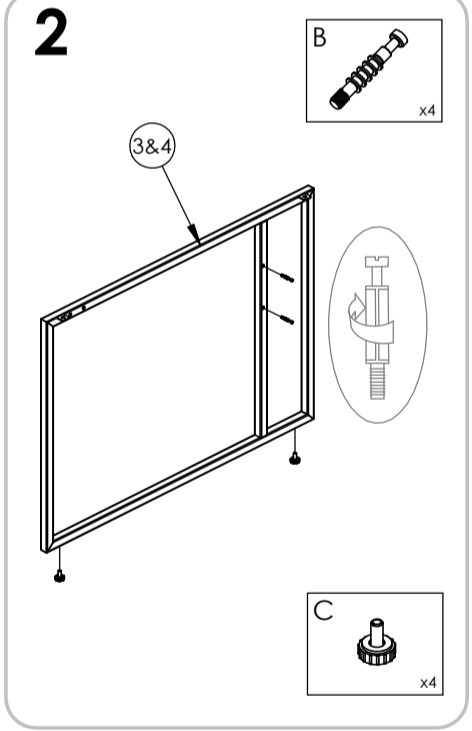
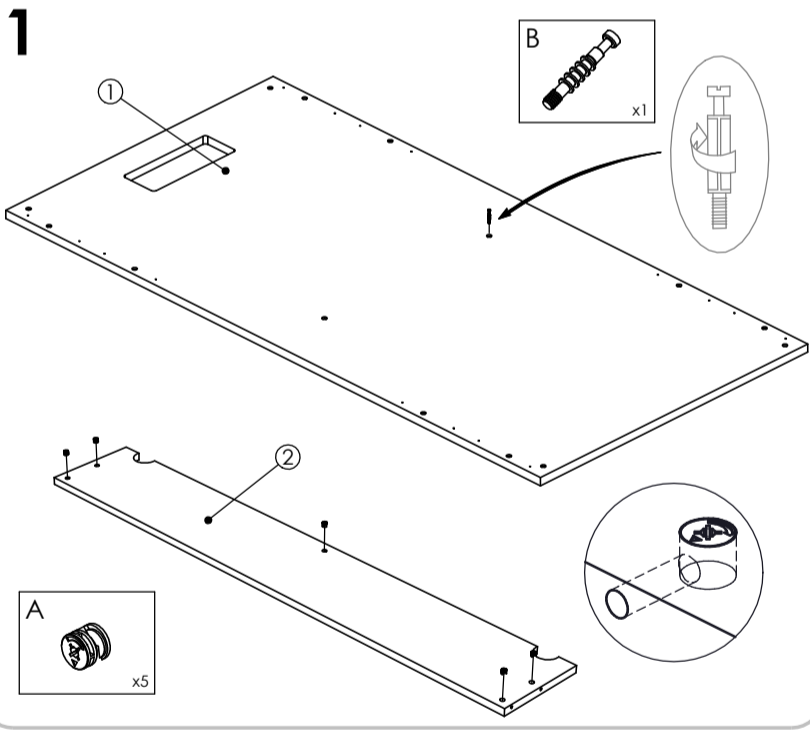
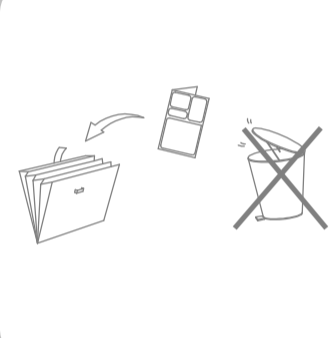
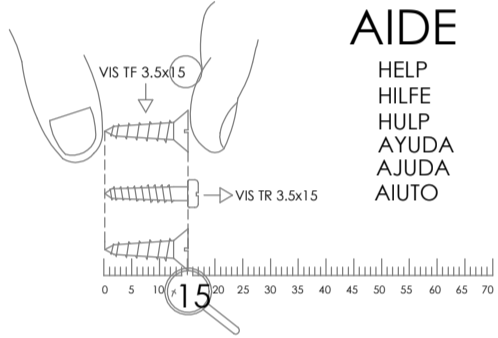

NOTICE DE MONTAGE
INSTRUCTIONS FOR ASSEMBLY
MONTAGEANLEITUNG
GEBRUIKSAANWIJZING
ISTRUZIONI DI MONTAGGIO
INSTRUCCIONES DE MONTAJE
INSTRUCCOES DE MONTAGEM

buronomic
FABRICANT FRANÇAIS
N° DV40709/02

CONCEPTION ET REALISATION BUREAU D'ETUDES BURONOMIC

GARANTIE (vices cachés)
_ Référence produit à nous communiquer impérativement en cas de litige :
Voir étiquette apposée au dos du produit

GARANTEE (defekt)
_ In the event of complaint, it is essential to mention the product reference :
See label affixed to the back of the product.

GARANTIE (fabrikationsfeil)
_ Im streitfall sit uns die produktreferenz mitzuteilen :
Siehe etikett auf produktdruckseite.

WAARBORG (de verborgen gebreken)
_ Vermeld in geval van klachten altijd het productnummer :
Zie label op de achterzijde van het product

GARANZIA (vizi occulti)
_ Specificare obbligatoriamente il riferimento prodotto in caso di contestazioni :
Si veda l'etichetta applicata dietro il prodotto

GARANTIA (defectos ocultos)
_ Referencia de producto citese obligatoriamente en caso de reclamacion :
Ver etiqueta en la parte posterior del producto.

GARANTIA (vices ocultos)
_ Em caso de reclamacao indiqu-nos imperativamente a referencia do produto :
Ver etiqueta fixada na parte posterior do produto

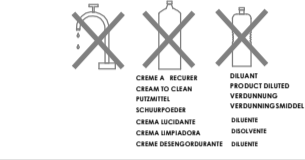
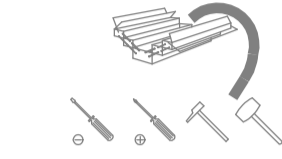
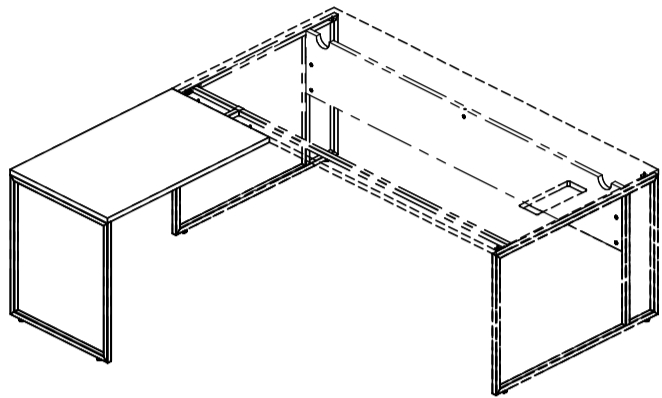
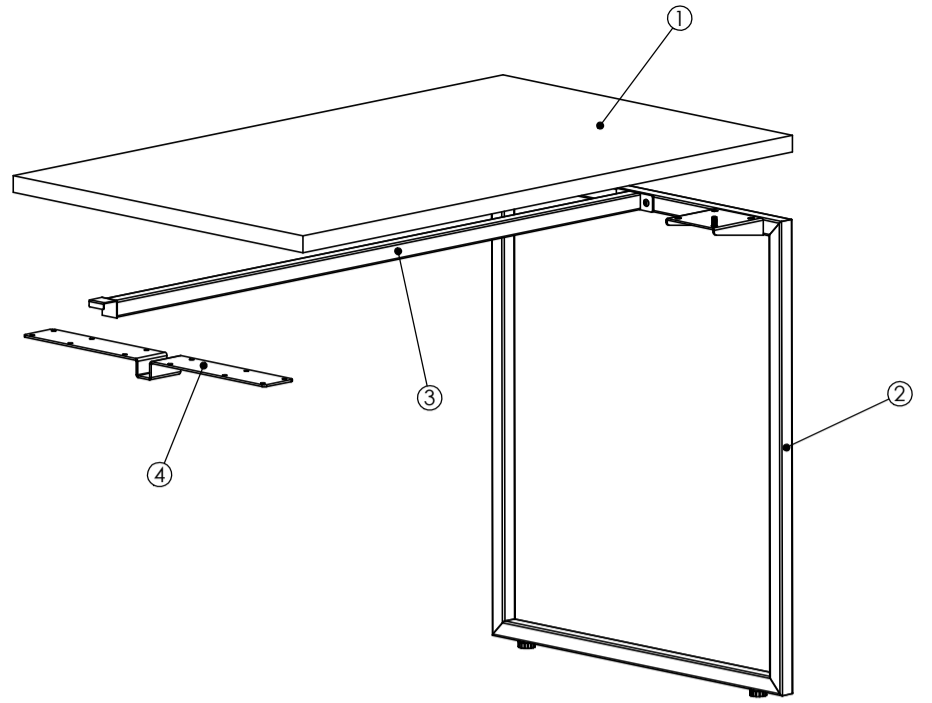

NOMENCLATURE

(Parts list)
(Stückliste)
(Onderdelenlijst)
(Nomenclatura)
(Lista de peças)

Rep.	Pièce	Qté
1	TOP	1
2	PIED de RETOUR	1
3	TRAVERSE RETOUR	1
4	PLATINE DE LIAISON	1

QUINCAILLERIE

(Hardware)
(Beschläge)
(Izerwaren)
(Ferramentas)
(Quinquilharia)

Rep.	Pièce	Qté	A	B	C
A	VERIN Ø25 M8X17	6			
B	VIS TBHc M6x10	2			
C	VIS TBHc M6x16	8			
D	Clé 6 pans 4mm	1			
			G	H	I
			J	K	L
			M	N	O
			P	Q	R

AIDE

HELP
HILFE
HULP
AYUDA
AJUDA
AIUTO

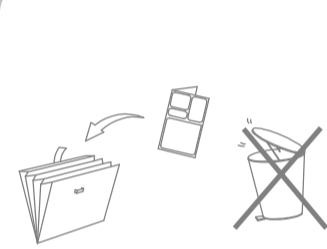
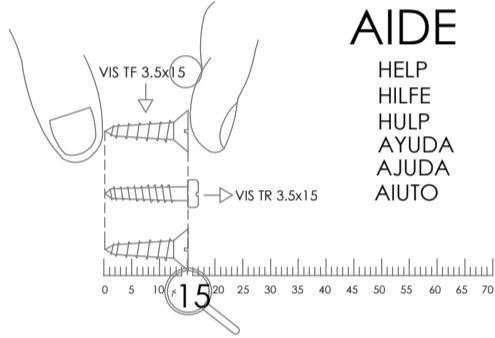

1

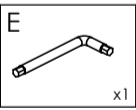
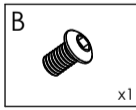
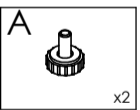
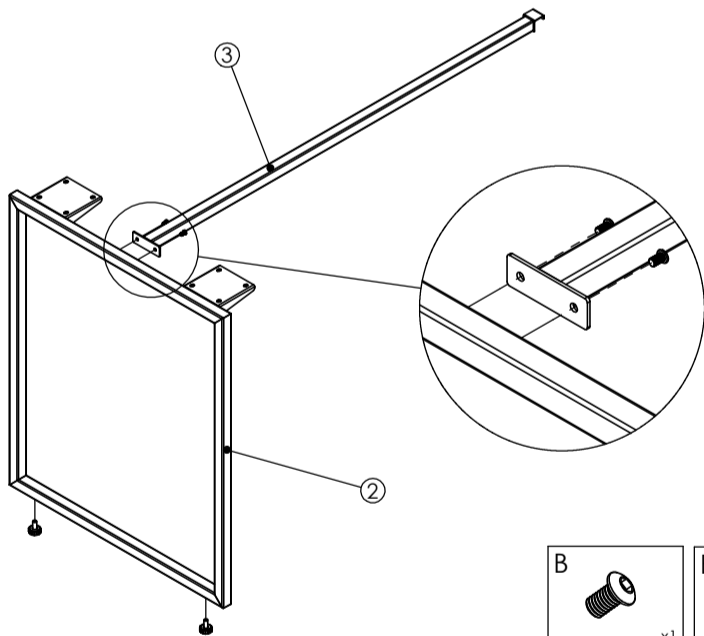

2

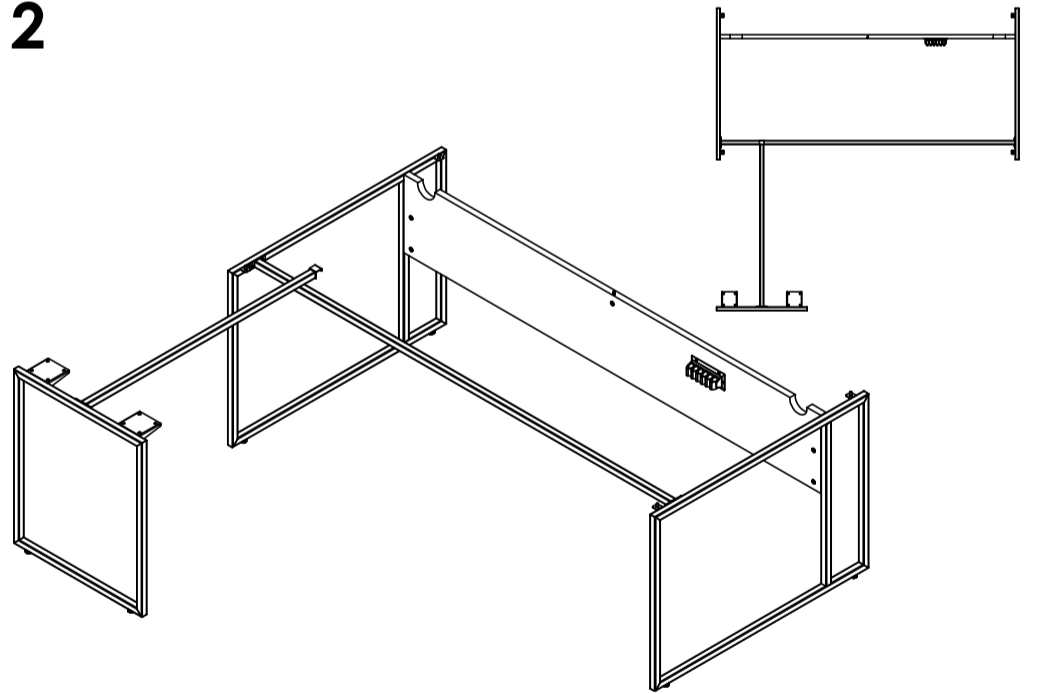

3

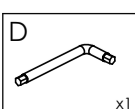
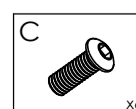
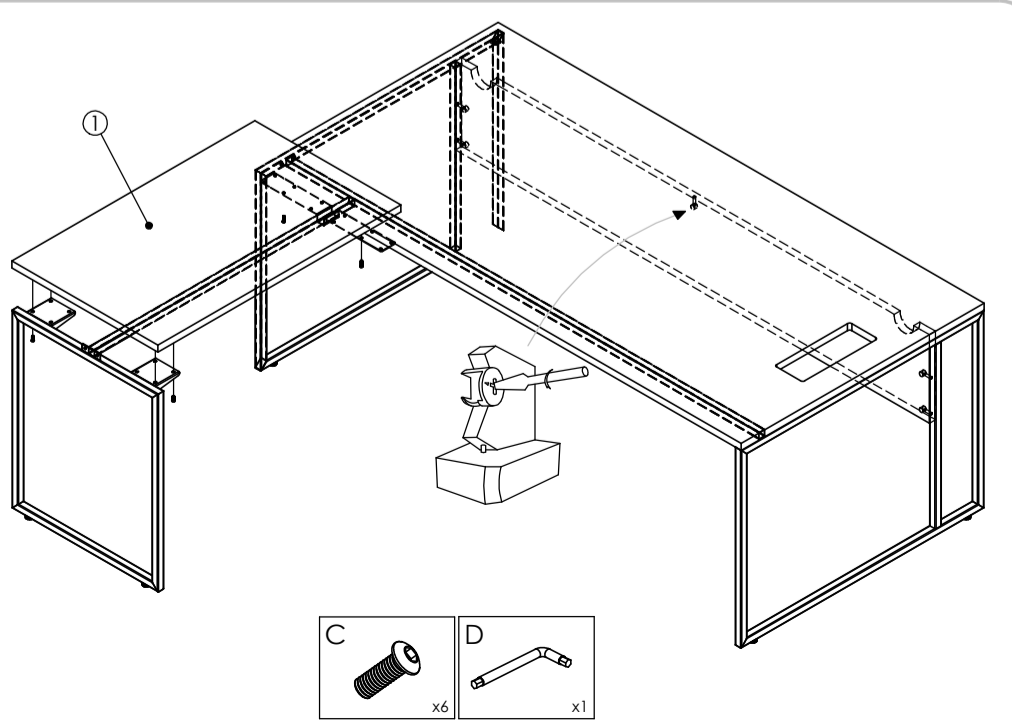
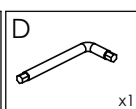
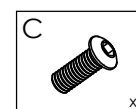
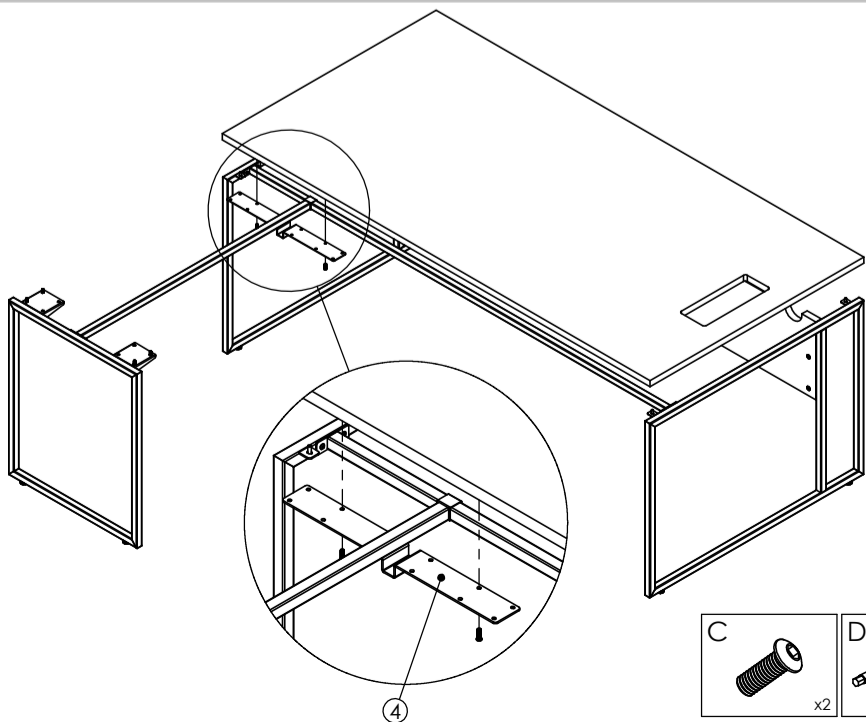

NOTICE DE MONTAGE
INSTRUCTIONS FOR ASSEMBLY
MONTAGEANLEITUNG
GEBRUIKSAANWIJZING
ISTRUZIONI DI MONTAGGIO
INSTRUCCIONES DE MONTAJE
INSTRUÇÕES DE MONTAGEM

buronomic
FABRICANT FRANÇAIS
N° DV40713/01

CONCEPTION ET REALISATION BUREAU D'ETUDES BURONOMIC

GARANTIE (voies cachées)
_ Référence produit à nous communiquer impérativement en cas de litige :
Voir étiquette apposée au dos du produit

GARANTIE (defekt)
_ In the event of complaint, it is essential to mention the product reference :
See label affixed to the back of the product.

GARANTIE (fabrikationsfeil)
_ Im streifall sit uns die produktreferenz mitzuteilen :
Siehe etikett auf produktrückseite.

WAARBORG (de verborgen gebreken)
_ Vermeld in geval van klachten altijd het productnummer :
Zie label op de achterzijde van het product

GARANZIA (vizi occulti)
_ Specificare obbligatoriamente il riferimento prodotto in caso di contestazioni :
Si veda l'etichetta applicata dietro il prodotto

GARANTIA (defectos ocultos)
_ Referencia de producto citese obligatoriamente en caso de reclamacion :
Ver etiqueta en la parte posterior del producto.

GARANTIA (vizi oculte)
_ Em caso de reclamação indiqu-nos imperativamente a referência do produto :
Ver etiqueta fixada na parte posterior do produto

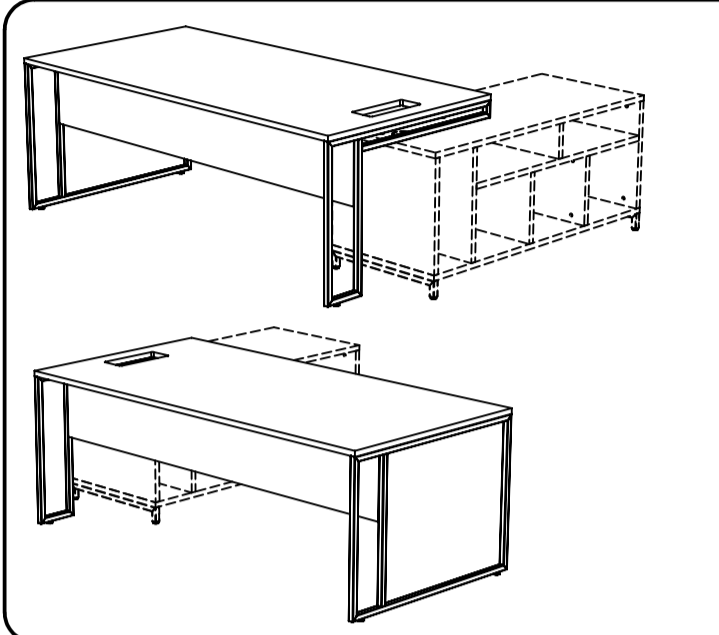
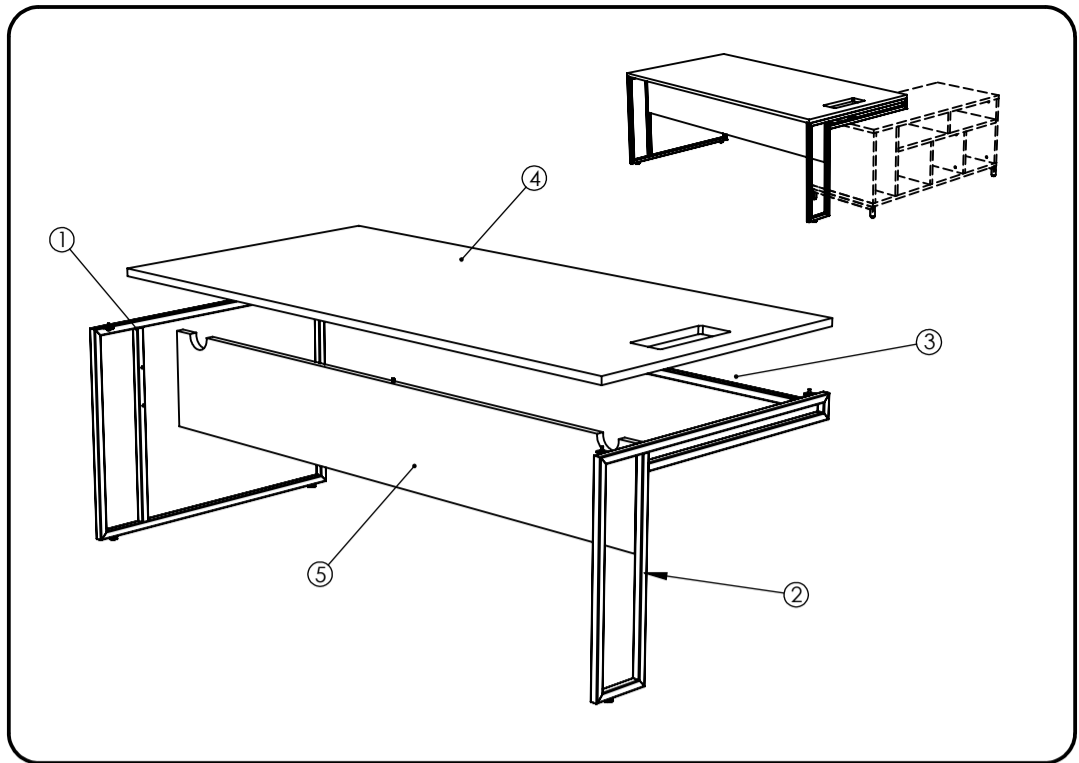

x1 25 Mn

CHIFFON DOUX
SOFT RAG
LAPPEN
ZACHTE DOEK
PANNINO MORBIDO
PAÑO SUAVE
FANO MACIO

SAYON SOAP
SEIFE
SAPONE
JABON
SABAO

CIRE
WAX
WACHS
WAS
CERA

NOMENCLATURE (Parts list)
(Stückliste)
(Onderdelenlijst)
(Nomenclatura)
(Lista de peças)

Rep.	Pièce	Qté
1	PIED 1000	1
2	PIED DE RETOUR CABINET	1
3	TRAVERSE	1
4	PLAN DE TRAVAIL TOP ACCESS	1
5	VDF	1

QUINCAILLERIE (Hardware)
(Beschläge)
(Ijzerwaren)
(Ferramentas)
(Herrajes)
(Quinquilharia)

Rep.	Pièce	Qté	A	B	C
A	Excentrique Ø15	5			
B	Goujon métal	5			
C	VERIN Ø25 M8X17	3			
D	VIS TCHC M6x16	4			
E	VIS TBHc M6x16	4			
F	Cache excent.	5			
G	Clé 6 pans 4mm	1			
H	Clé 6 pans 5mm	1			
J					
K					
L					
M					
N					
O					
P					
Q					
R					

AIDE
HELP
HILFE
HULP
AYUDA
AJUDA
AIUTO

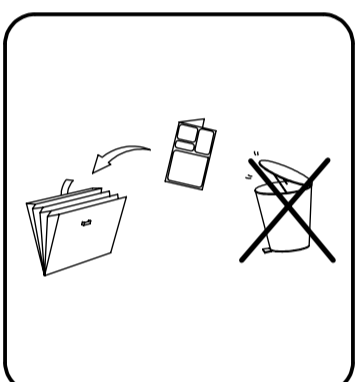

1

2

3

4

5

NOTICE DE MONTAGE
INSTRUCTIONS FOR ASSEMBLY
MONTAGEANLEITUNG
GEBRUIKSAANWIJZING
ISTRUZIONI DI MONTAGGIO
INSTRUCCIONES DE MONTAJE
INSTRUCOES DE MONTAGEM

buronomic

N° DV40716/02

CONCEPTION ET REALISATION BUREAU D'ETUDES BURONOMIC

GARANTIE (vices cachés)
_ Référence produit à nous communiquer impérativement en cas de litige :
Voir étiquette apposée au dos du produit

GARANTIE (defekt)
_ In the event of complaint, it is essential to mention the product reference :
See label affixed to the back of the product.

GARANTIE (fabrikationsfeil)
_ Im streifall sit uns die produktreferenz mitzuteilen :
Siehe etikett auf produktuckseite.

WAARBORG (de verborgen gebreken)
_ Vermeld in geval van klachten altijd het productnummer :
Zie label op de achterzijde van het product

GARANZIA (vizi occulti)
_ Specificare obbligatoriamente il riferimento prodotto in caso di contestazioni :
Si veda l'etichetta applicata dietro il prodotto

GARANTIA (defectos ocultos)
_ Referencia de producto citese obligatoriamente en caso de reclamacion :
Ver etiqueta en la parte posterior del producto.

GARANTIA (vices ocultas)
_ Em caso de reclamacao indiqu-nos imperativamente a referencia do produto :
Ver etiqueta fixada na parte posterior do produto

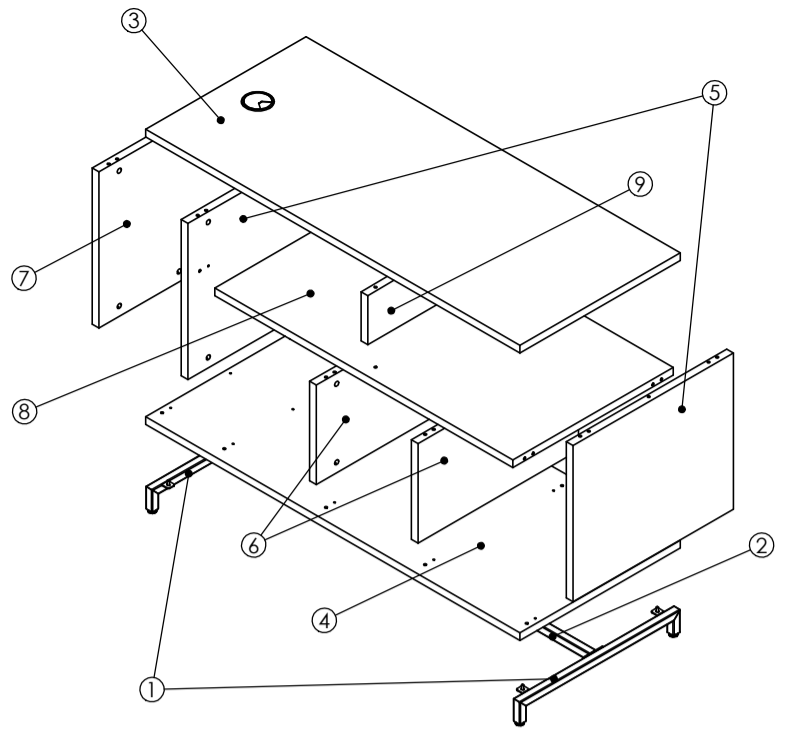
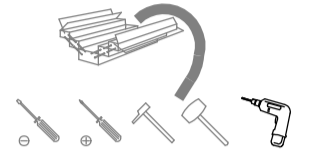
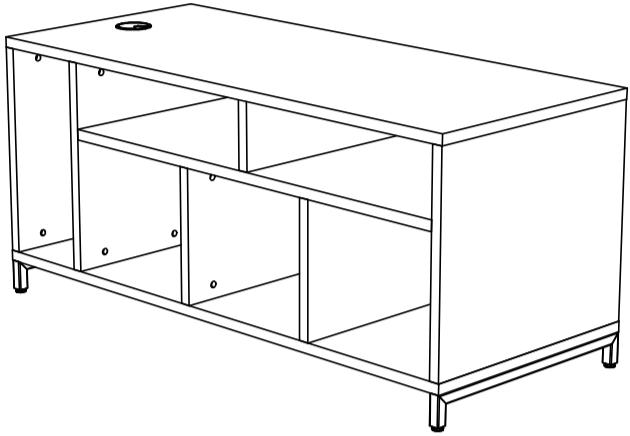

NOMENCLATURE

(Parts list)
(Stückliste)
(Onderdelenlijst)
(Nomenclatura)
(Lista de peças)

Rep.	Pièce	Qté
1	PIED MEUBLE BAS	2
2	TRAVERSE	1
3	DESSUS	1
4	FOND	1
5	SEPARATION COTE	2
6	SEPARATION BASSE	2
7	SEPARATION COTE UC	1
8	TABLETTE	1
9	SEPARATION HAUTE	1

QUINCAILLERIE

(Hardware)
(Beschläge)
(Ijzerwaren)
(Ferramentas)
(Quinquilharia)

Rep.	Pièce	Qté	A	B	C
A	Excentrique court	30			
B	Goujon bois	30			
C	VERIN Ø25 M8X17	4			
D	VIS TBHC M6x10	4			
E	VIS TCHC M6x16	4			
F	Cache excent.	30			
G	VIS TBHC M8x35	2			
H	GOUJONS BOIS	28			
I	Clé 6 pans 4mm	1			
J	Clé 6 pans 5mm	1			
			P	Q	R

AIDE

HELP
HILFE
HULP
AYUDA
AJUDA
AIUTO

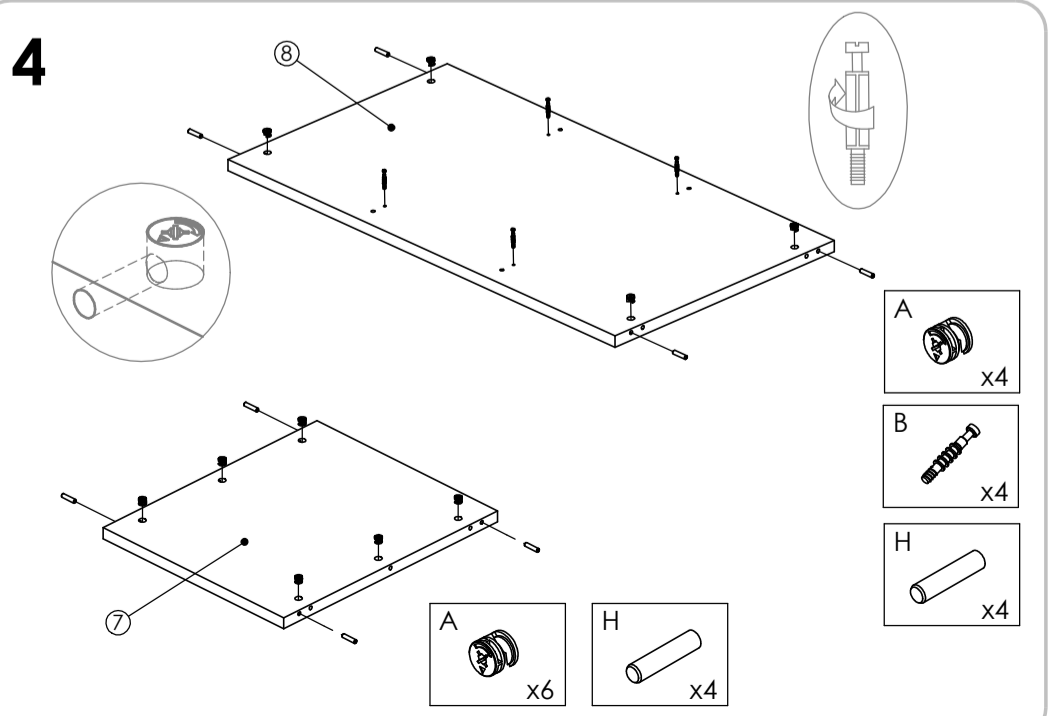
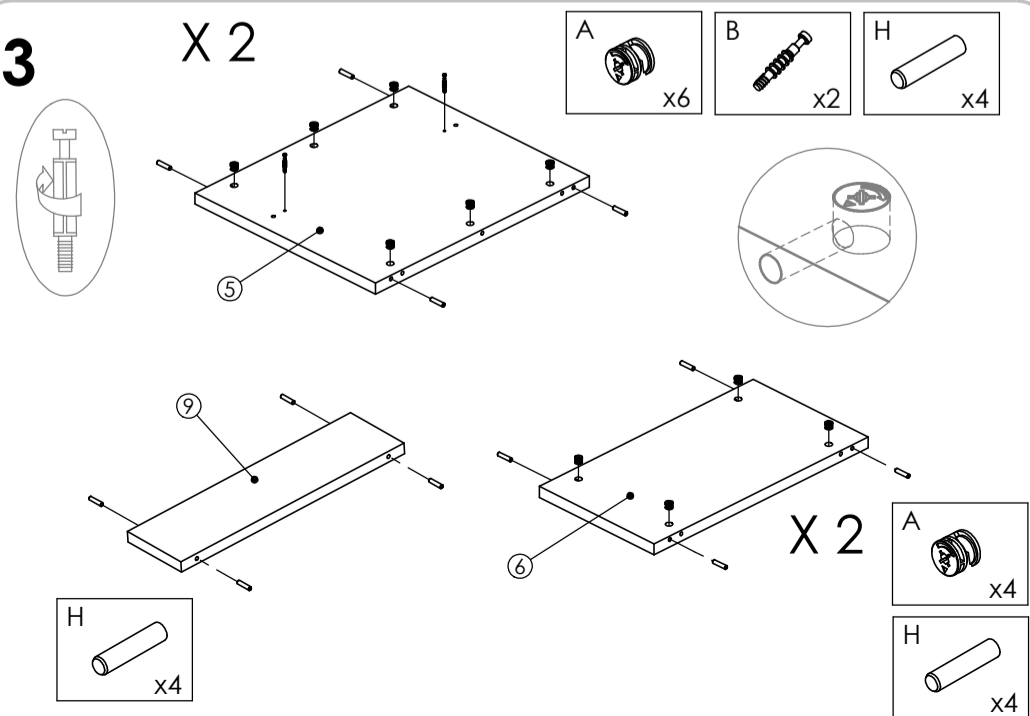
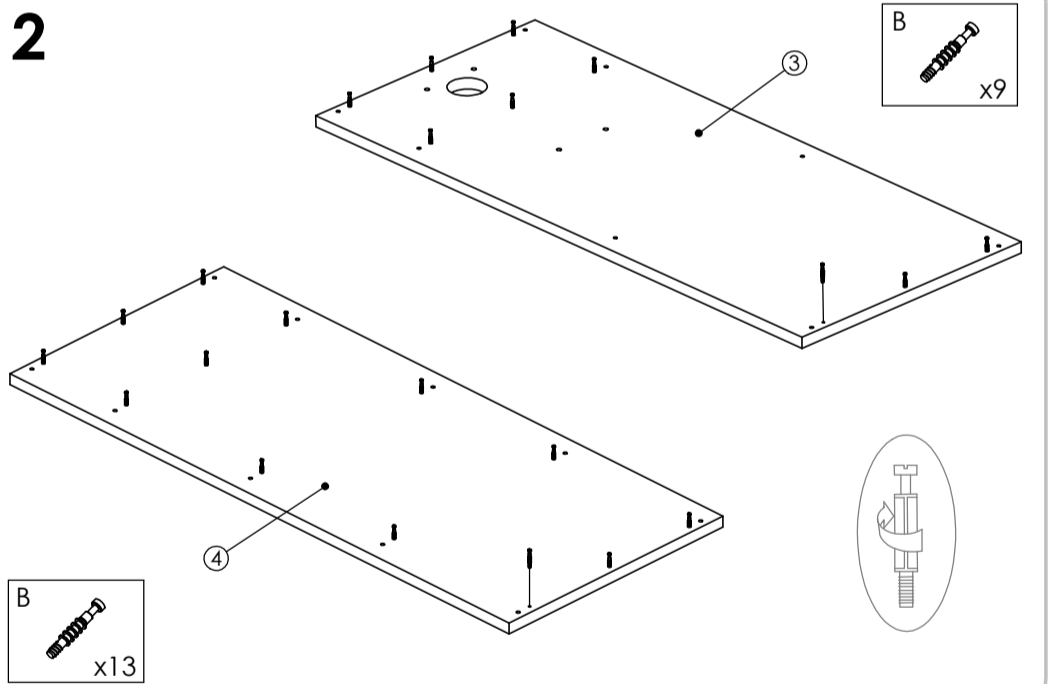
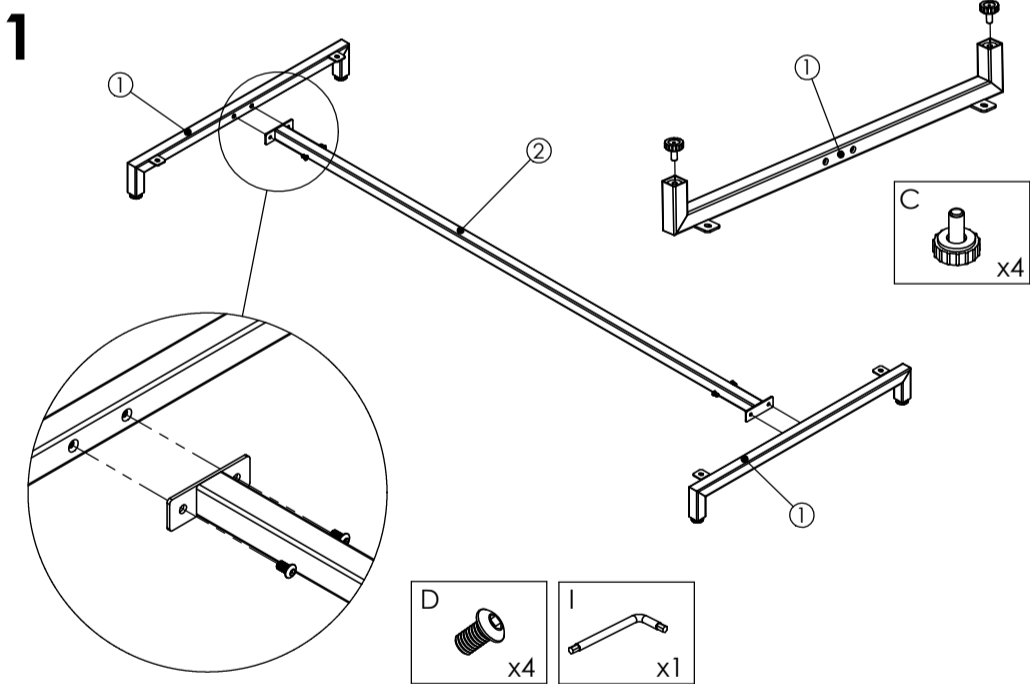
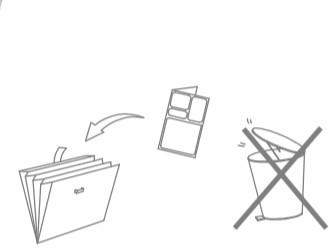
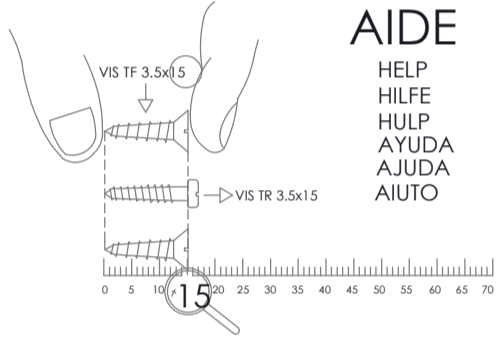

5

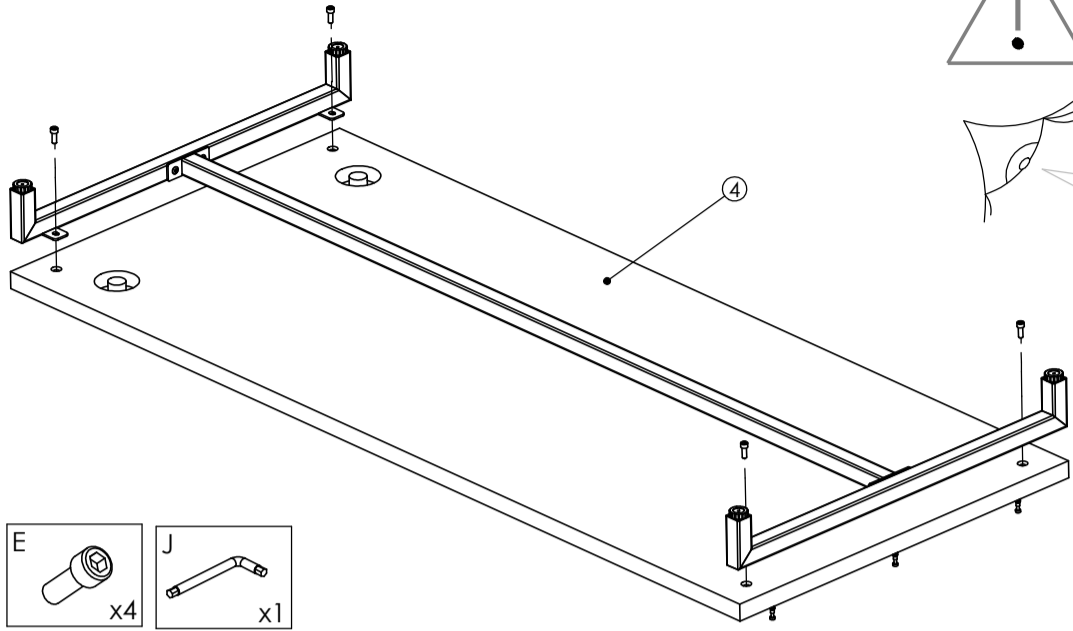

6

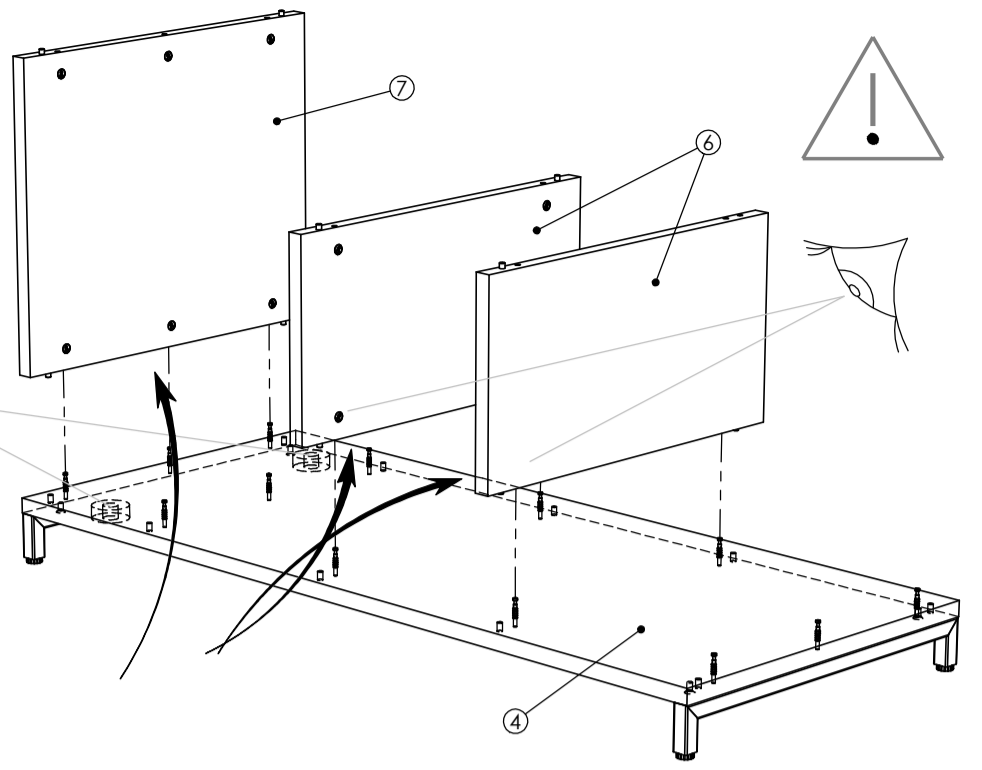

7

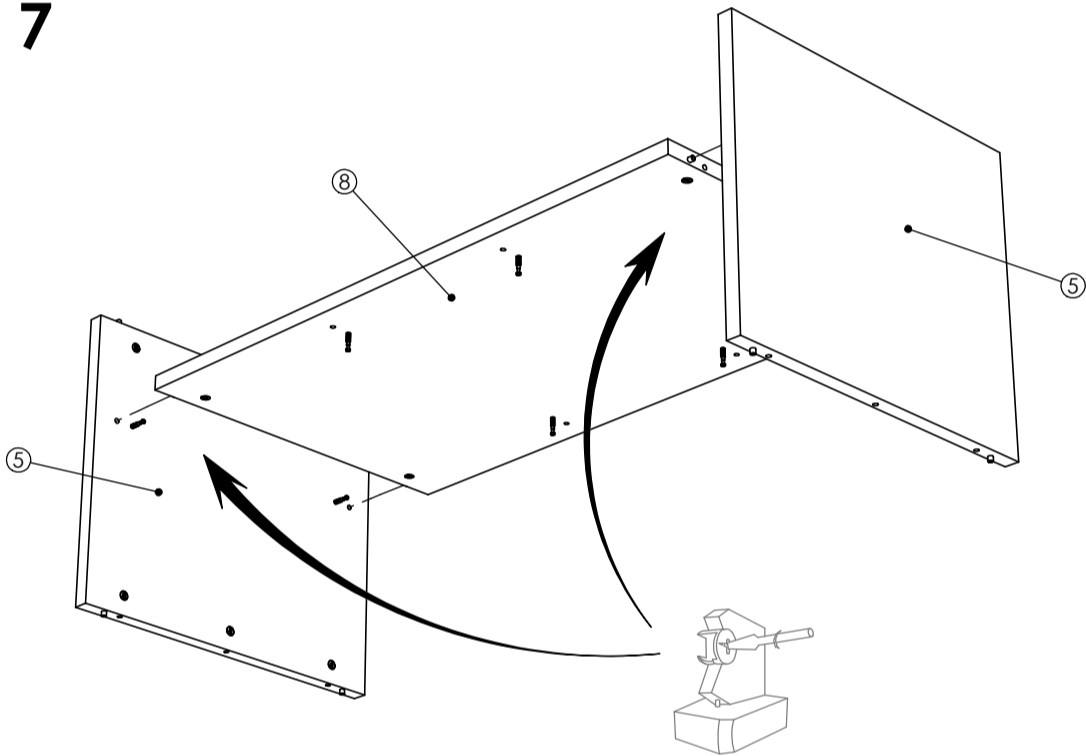

8

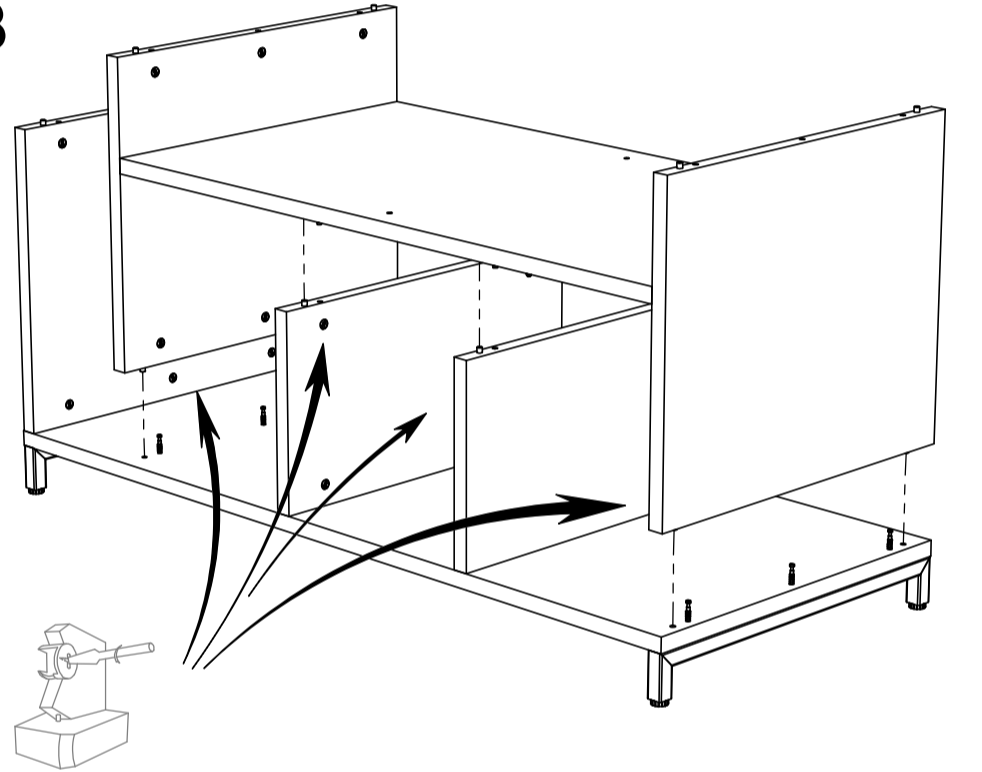

9

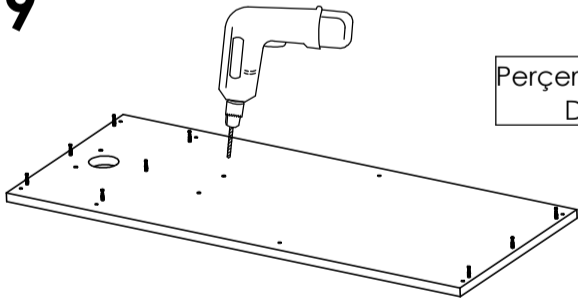

Perçer les deux trous pré-débochant
Drill the two pre-drilled holes

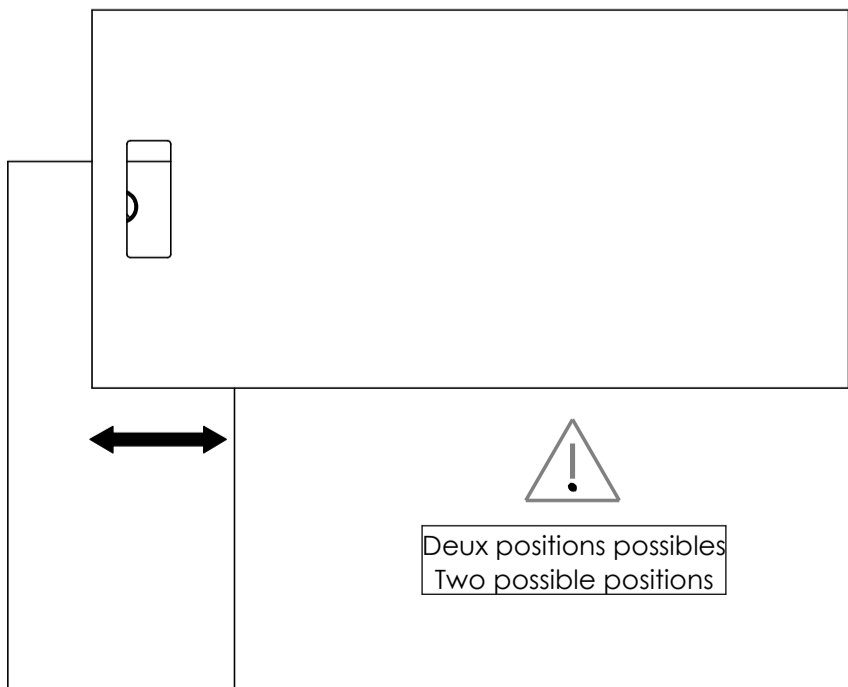

Deux positions possibles
Two possible positions

10

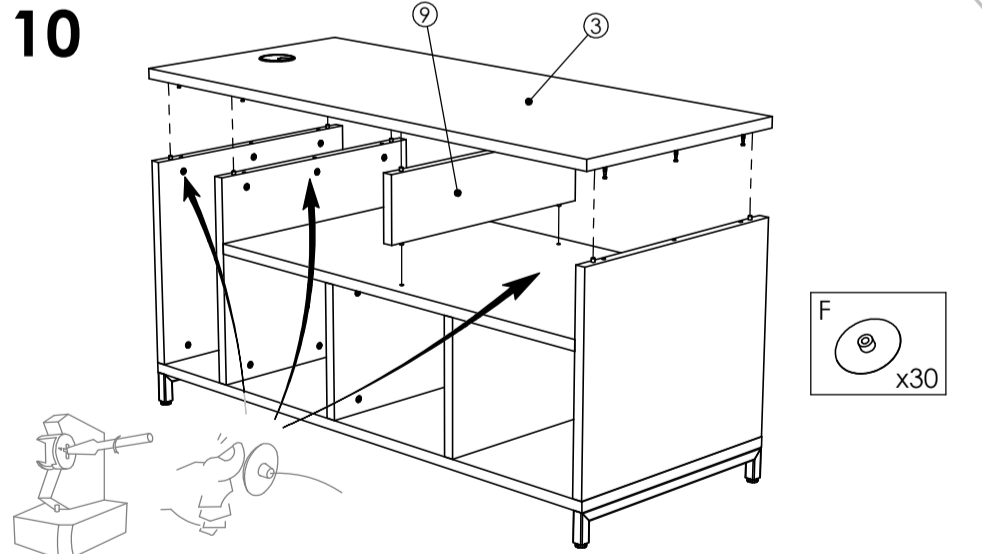

11 DÉTAIL C
ECHELLE 1 : 16

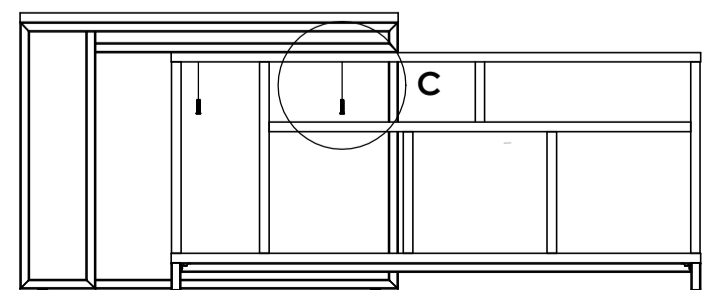

F
x30

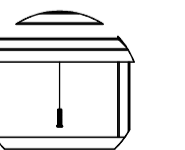

G
x2

J
x1

NOTICE DE MONTAGE
 INSTRUCTIONS FOR ASSEMBLY
 MONTAGEANLEITUNG
 GEBRUIKSAANWIJZING
 ISTRUZIONI DI MONTAGGIO
 INSTRUCIONES DE MONTAJE
 INSTRUCOES DE MONTAGEM

buronomic

N° DV40720

CONCEPTS ET REALISATIONS BUREAU D'ETUDES BURONOMIC

GARANTIE (Garantie)
 - Référence produit à nous communiquer impérativement en cas de litige :
 Voir étiquette apposée au dos du produit

GARANTEE (Garantie)
 - In the event of complaint, it is essential to mention the product reference :
 See label affixed to the back of the product.

GARANTIE (Garantie)
 - Im streitfall sit uns die produktreferenz mitzuteilen :
 Siehe etikett auf produktdruckseite.

WAARBORG (Garantie)
 - Vermeld in geval van klachten altijd het productnummer :
 Zie label op de achterzijde van het product

GARANZIA (Garanzia)
 - Specificare obbligatoriamente il riferimento prodotto in caso di contestazioni :
 Si veda l'etichetta applicata dietro il prodotto

GARANTIA (Garantia)
 - Referencia de producto cite obligatoriamente en caso de reclamacion :
 Ver etiqueta en la parte posterior del producto.

GARANTIA (Garantia)
 - Em caso de reclamação indiqu-nos imperativamente a referência do produto :
 Ver etiqueta fixada na parte posterior do produto

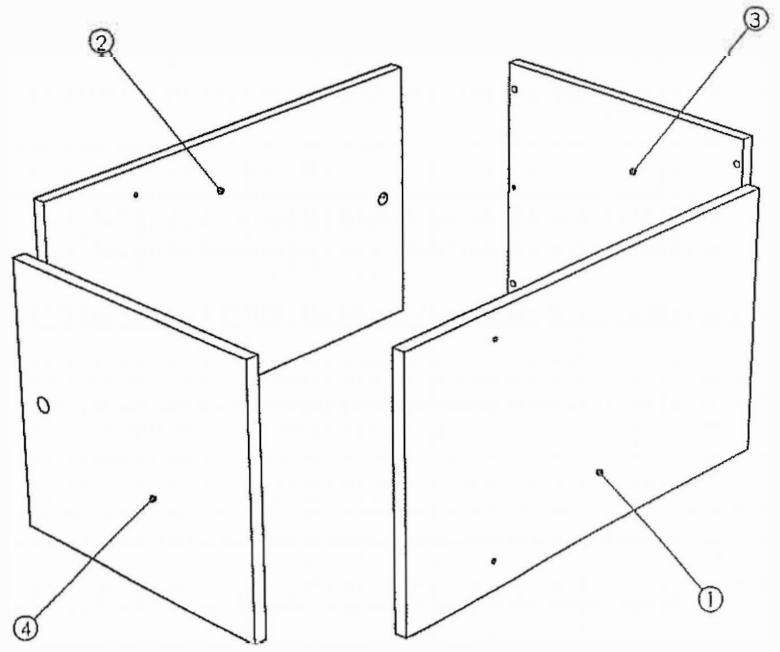
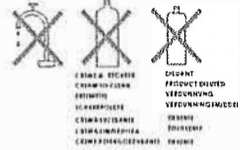
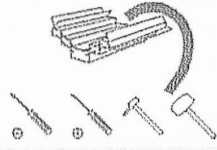
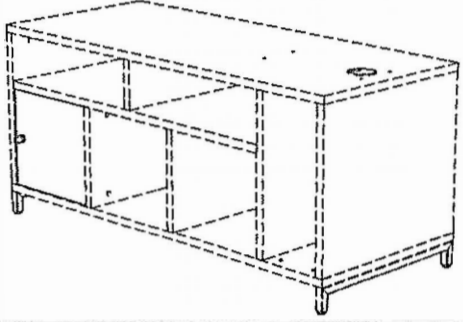
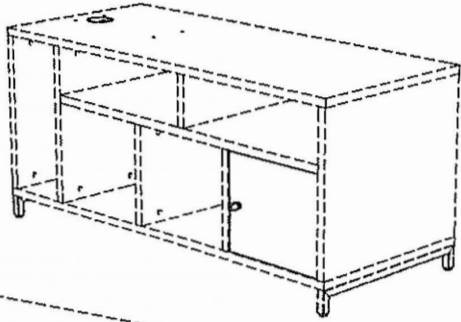

NOMENCLATURE

(Parts list)
 (Stückliste)
 (Onderdelenlijst)
 (Nomenclatura)
 (Lista de peças)

Rep.	Pièce	Qté
1	COTE CHARNIERES	1
2	COTE GACHE	1
3	PAR	1
4	PORTE	1

QUINCAILLERIE

(Hardware)
 (Beschläge)
 (Izerwaren)
 (Ferramentas)
 (Ferrejas)
 (Quinilharia)

Rep.	Pièce	Qté
A	Charniere	2
B	Serrure	1
C	Vis TF 3x20	2
D	Cale charnière	2
E	GACHE Tôle	1
F	VIS EURO St	2
G	Vis TR 3x13	1
H	Excentrique Ø15	2
I	Goujon bois	2
J	Vis 4x30	4
K	Cache exent.	2

AIDE

HELP
 HILFE
 HULP
 AYUDA
 AJUDA
 AIUTO

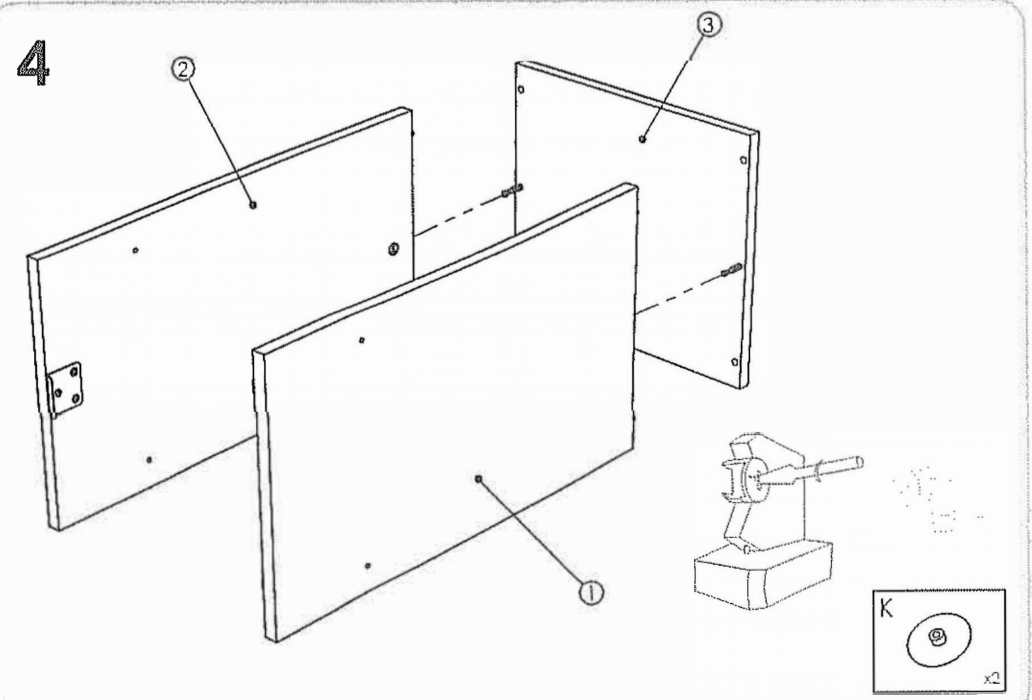
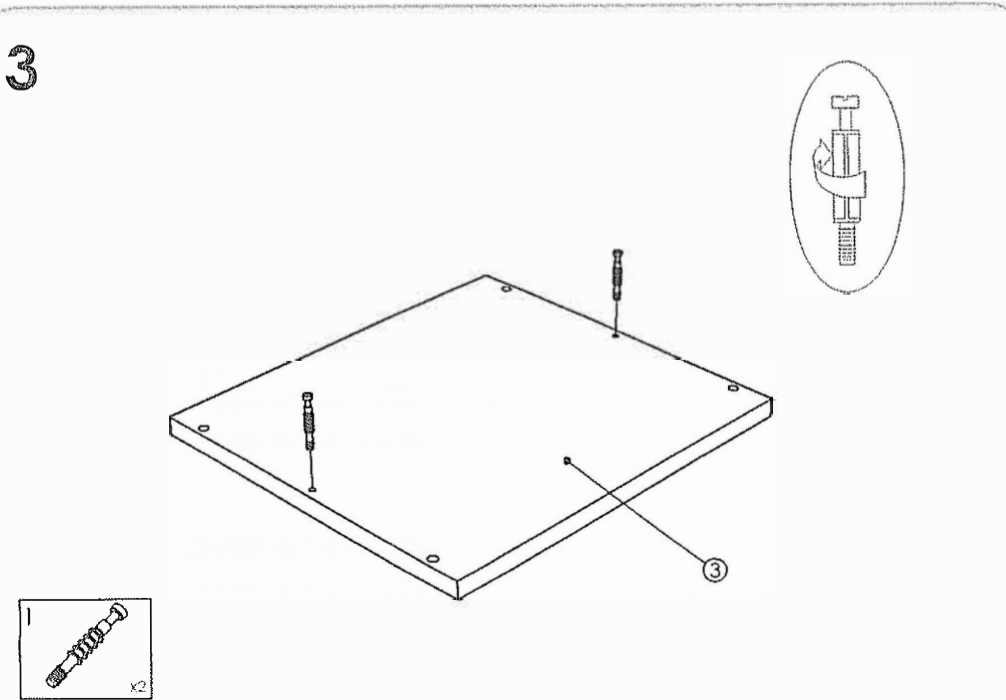
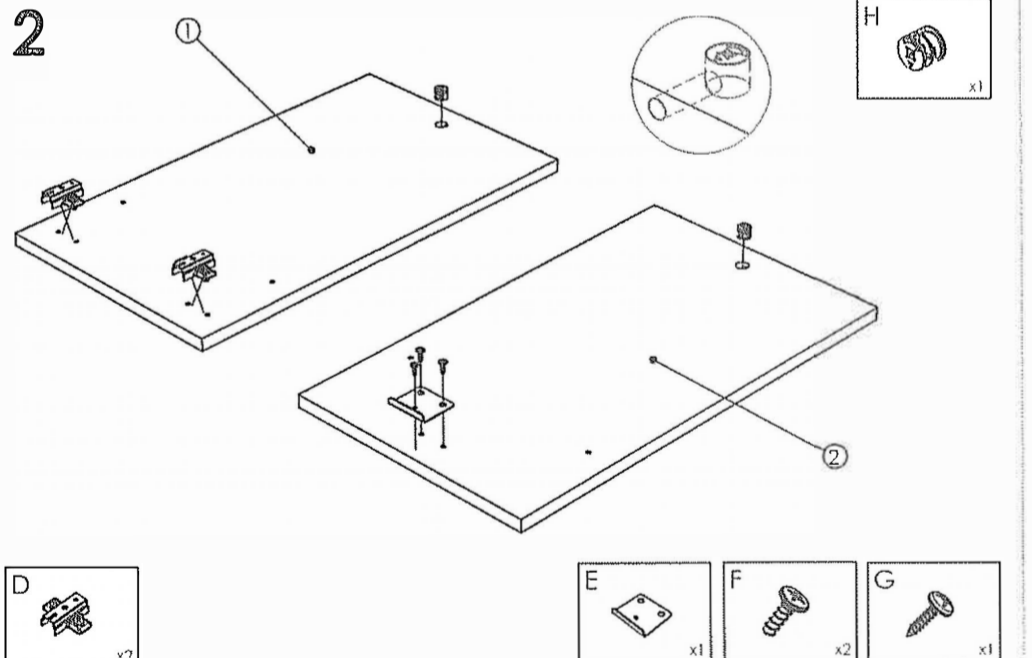
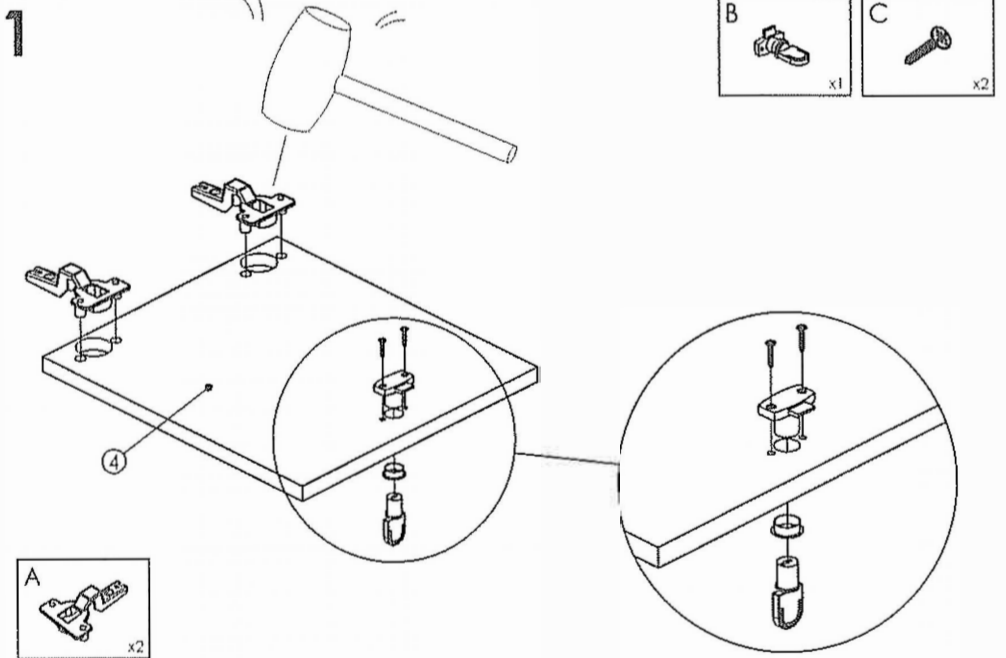
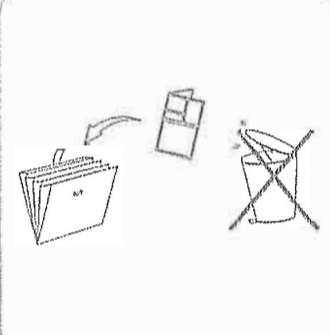
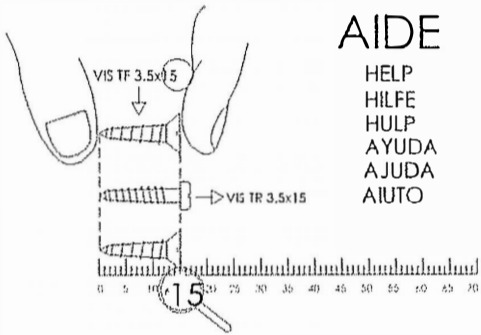

5

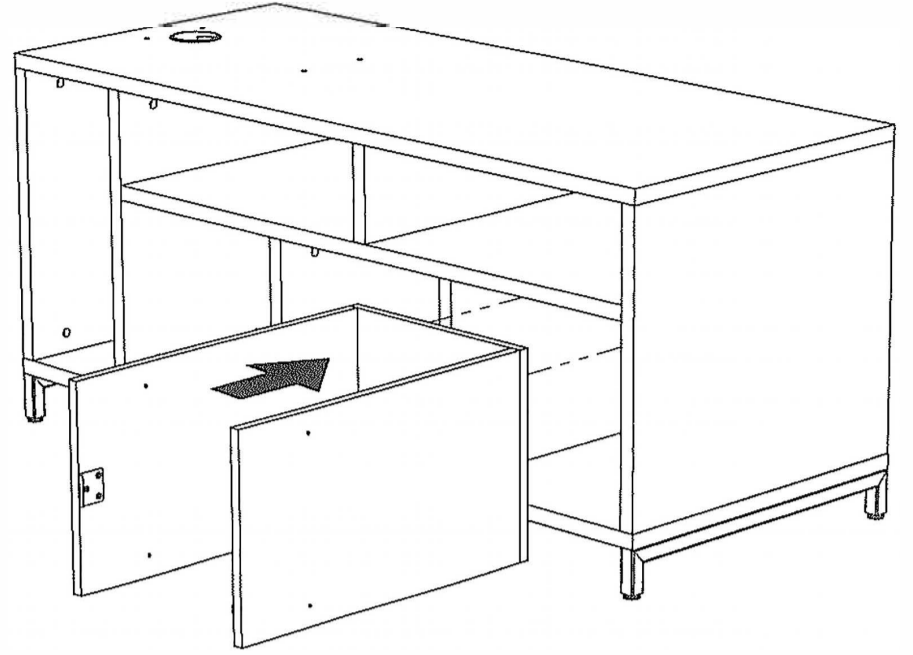
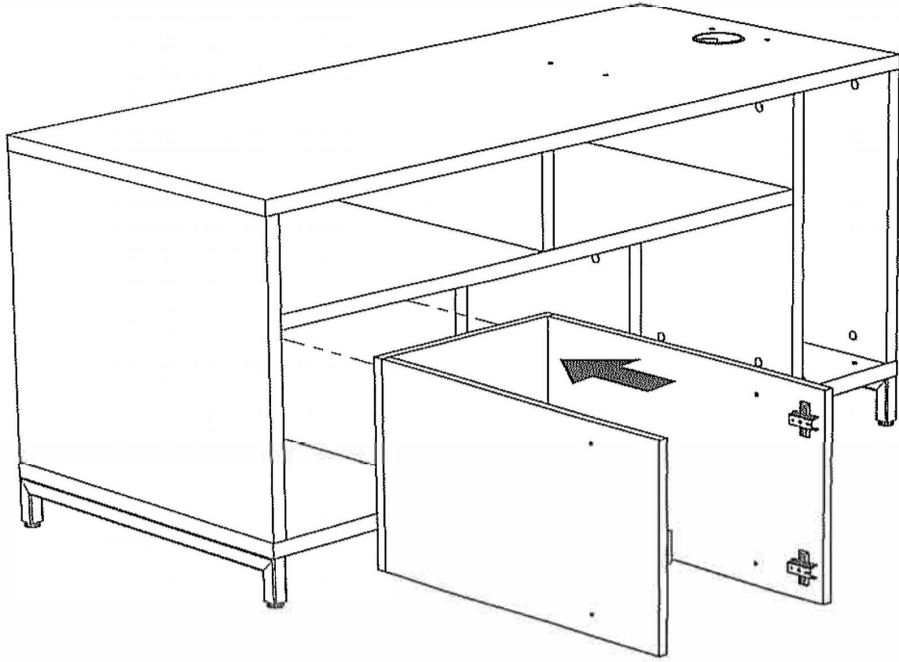

6

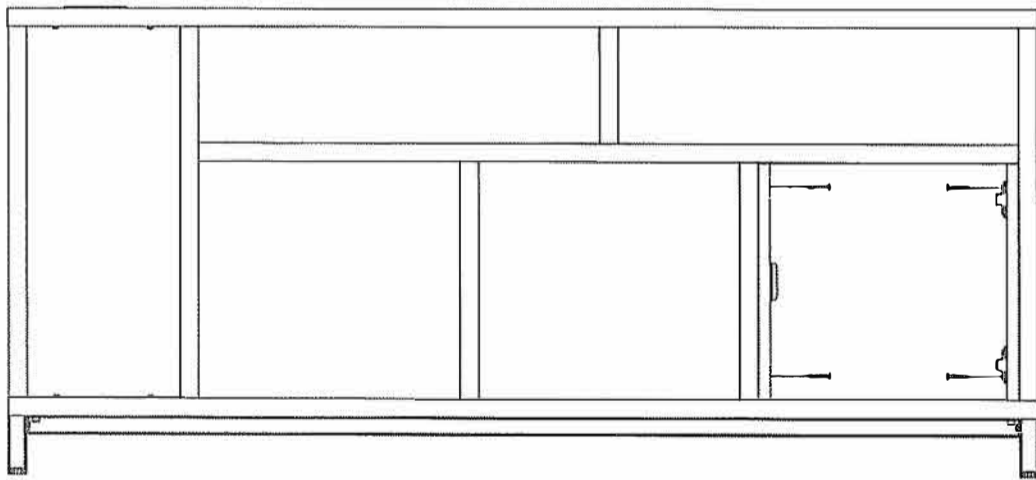
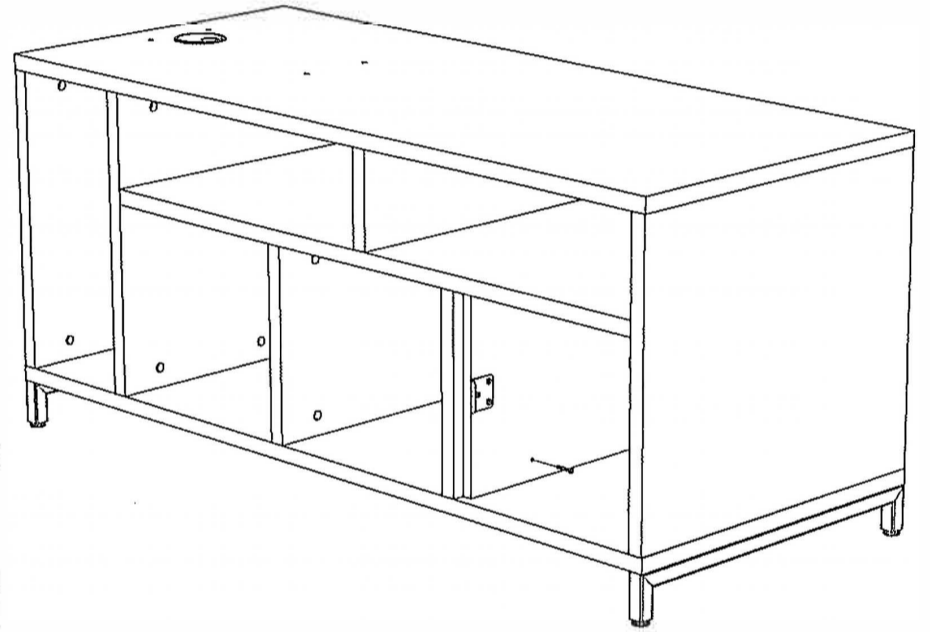
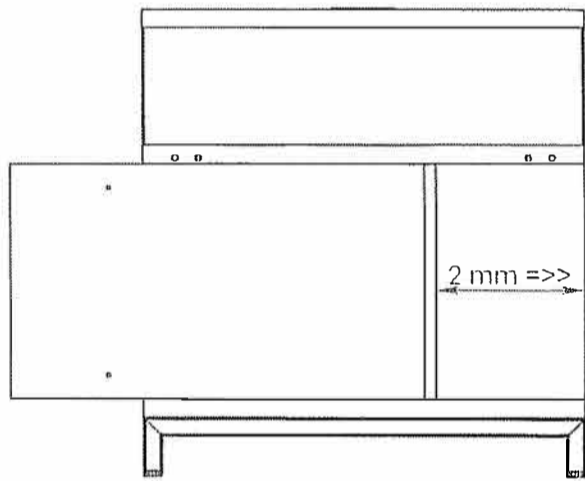

7

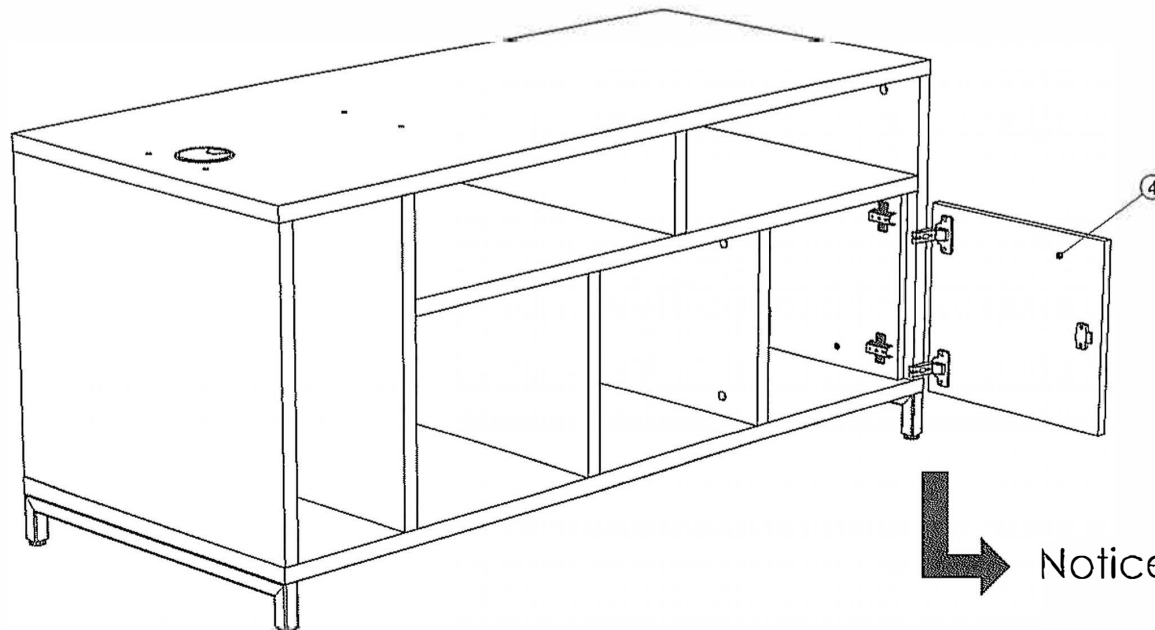

Notice DV40554

NOTICE DE MONTAGE
INSTRUCTIONS FOR ASSEMBLY
MONTAGEANLEITUNG
GEBRUIKSAANWIJZING
ISTRUZIONI DI MONTAGGIO
INSTRUCCIONES DE MONTAJE
INSTRUCOES DE MONTAGEM

buromomic

N° DV40721

CONCEPTION ET REALISATION BUREAU D'ETUDES BUROMOMIC

GARANTIE (warranty)
_ Réference produit à nous communiquer impérativement en cas de litige :
Voir étiquette apposée au dos du produit

GARANTEE (warranty)
_ In the event of complaint, it is essential to mention the product reference :
See label affixed to the back of the product.

GARANTIE (warranty)
_ im streitfall sit uns die produktreferenz mitzuteilen :
Siehe etikett auf produktrucksseite.

WAARBORG (warranty)
_ Vermeld in geval van klachten altijd het productnummer :
Zie label op de achterzijde van het product

GARANZIA (warranty)
_ Specificare obbligatoriamente il riferimento prodotto in caso di contestazioni :
Si veda l'etichetta applicata dietro il prodotto

GARANTIA (warranty)
_ Referencia de producto cite obligatoriamente en caso de reclamacion :
Ver etiqueta en la parte posterior del producto.

GARANTIA (warranty)
_ Em caso de reclamacao indiqu-nos imperativamente a referencia do produto :
Ver etiqueta fixada na parte posterior do produto

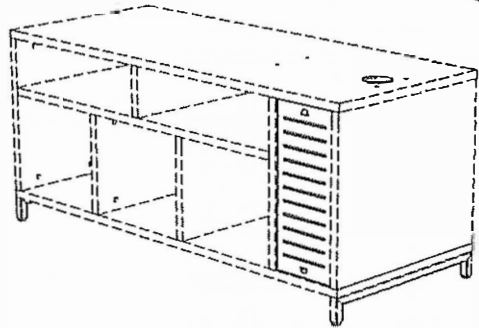
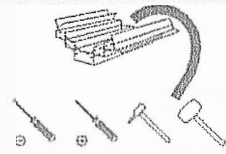
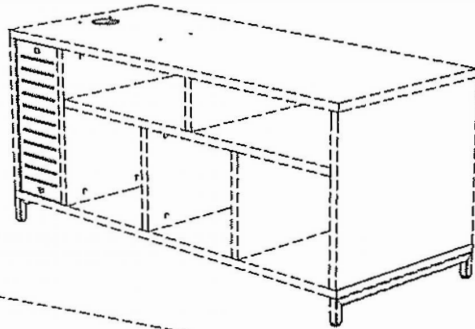
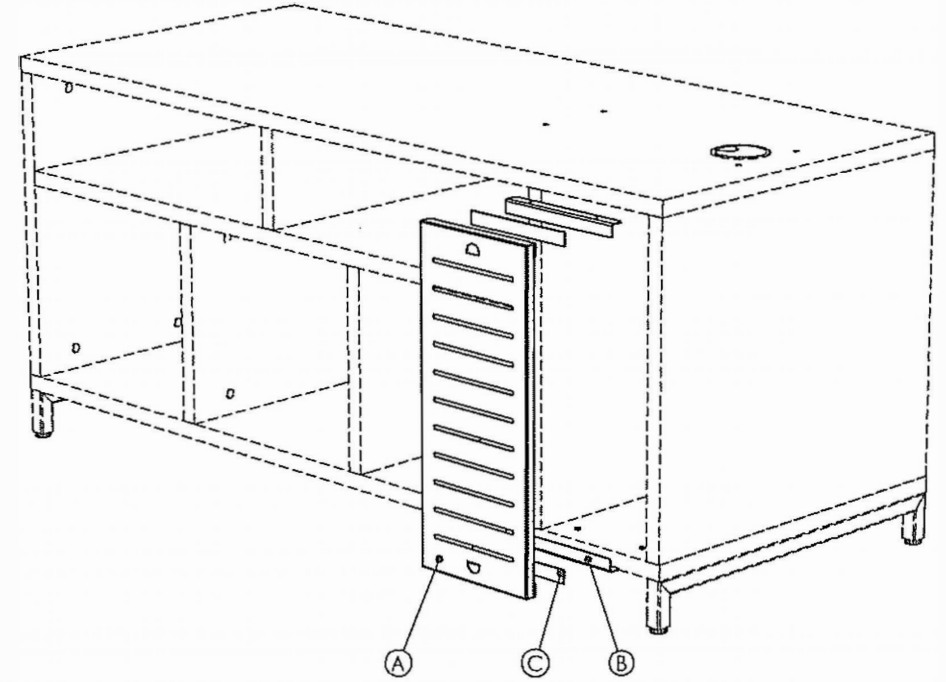

NOMENCLATURE

(Parts list)
(Stückliste)
(Onderdelenlijst)
(Nomenclatura)
(Lista de peças)

QUINCAILLERIE

(Hardware)
(Beschläge)
(Bewerfen)
(Ferramenta)
(Herrajes)
(Quinquilharia)

Rep.	Pièce	Qté
A	GRILLE AERATION	1
B	EQUERRE MAGNETIQUE	2
C	Magnétique	2
D	Vis TR 3,5x15	4

A	B	C
D	E	F
G	H	I
J	K	L
M	N	O
P	Q	R

AIDE

HELP
HILFE
HULP
AYUDA
AJUDA
AIUTO

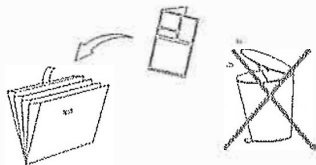
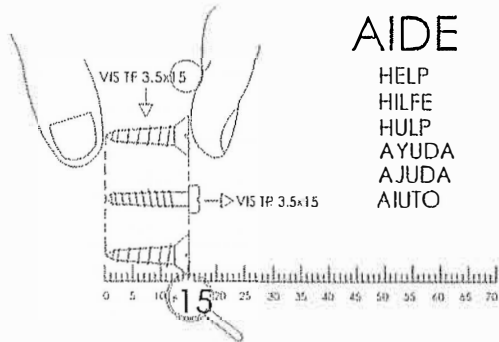

1

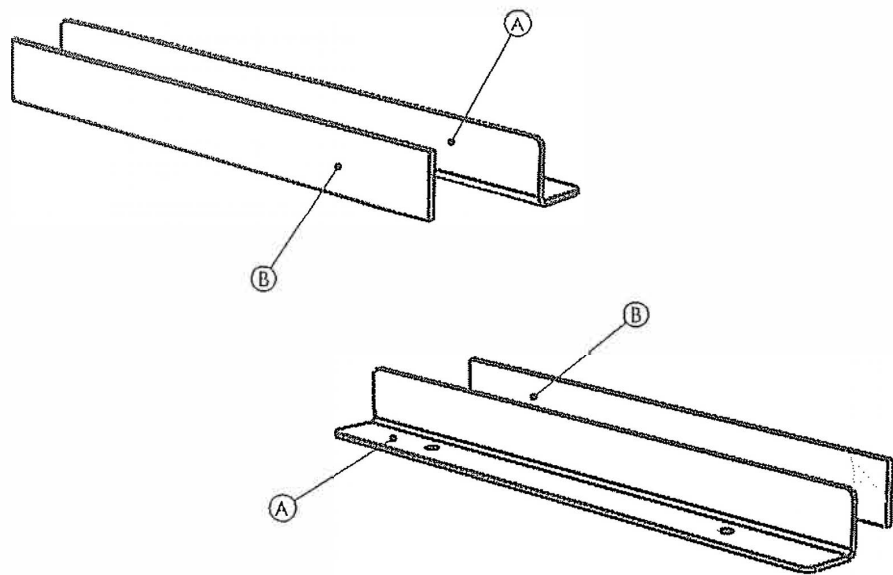

2

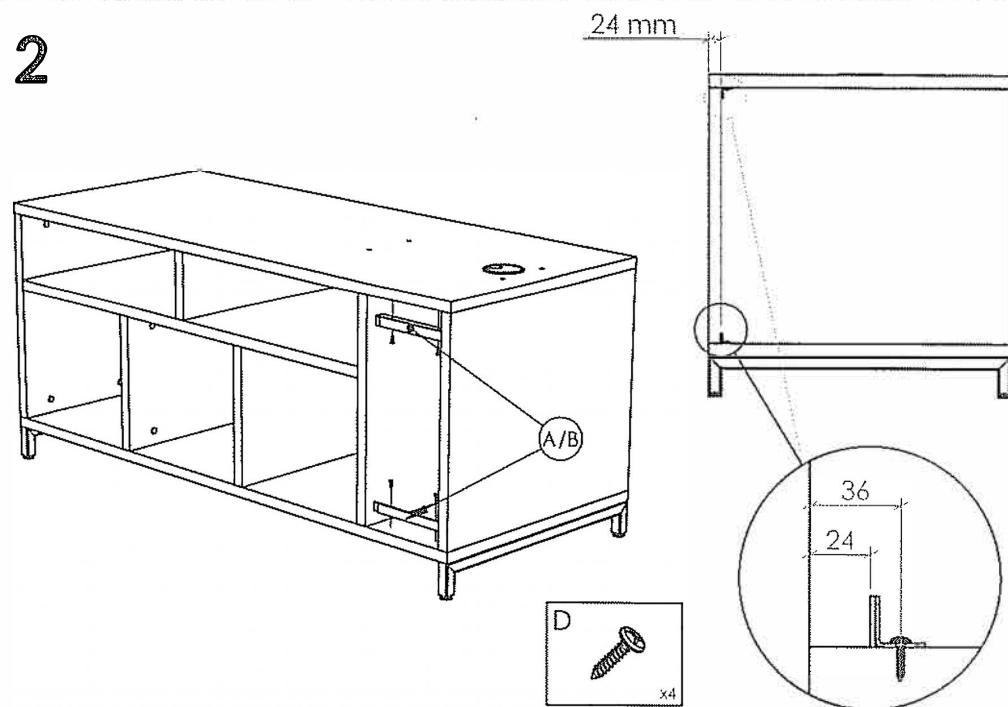

3

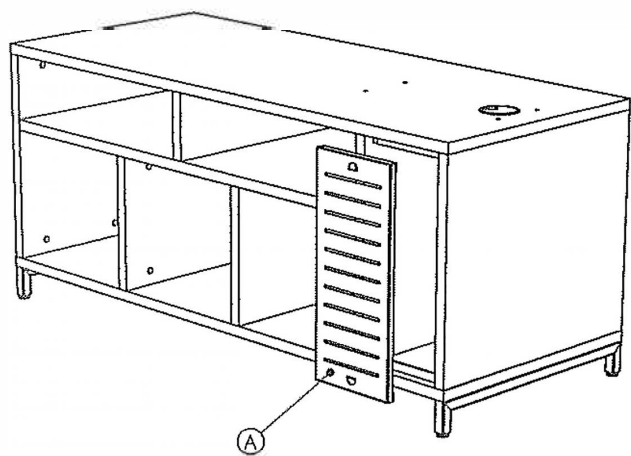

4

